

1	FURNITURE BOARD	2000x600x18 mm	1 pc
2	PLYWOOD	1525x1525x18 mm	1 pc
3	SHOVEL HANDLES	1200 mm	10 pc
4	ROPE	d7 mm	4,4 m
5	WOOD GLUE	0,25 l	1 pc
6	WHEELS	d75 mm	4 pc
7	WOOD OIL	0,25 l	1 pc
8	ACRYL PAINT		4 pc
9	SCREWS	60 mm	28 pc
		50 mm	16 pc
		15 mm	16 pc

Cutting.
Furniture board for the chest.

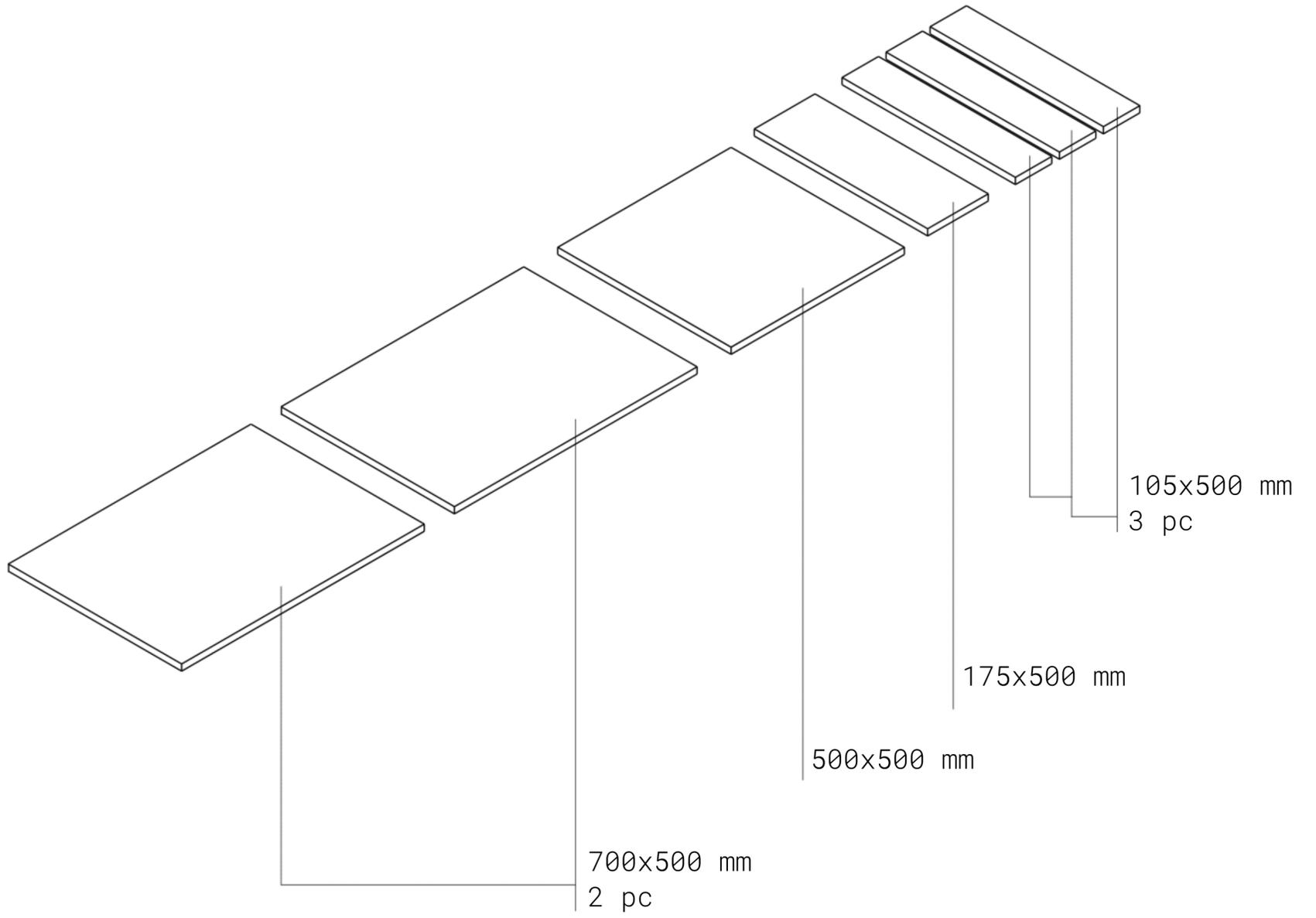

105x500	105x500	105x500	
700x500	700x500	500x500	175x500

Cutting.*

Plywood for elements with a base for the chest.

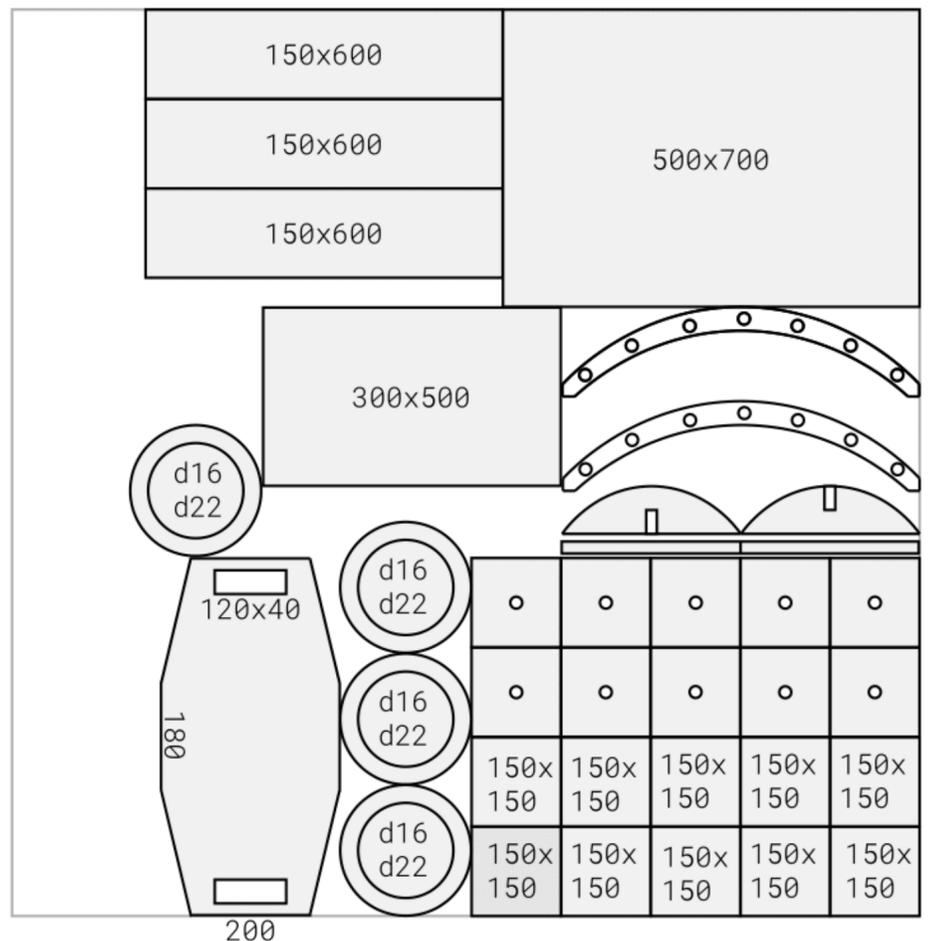
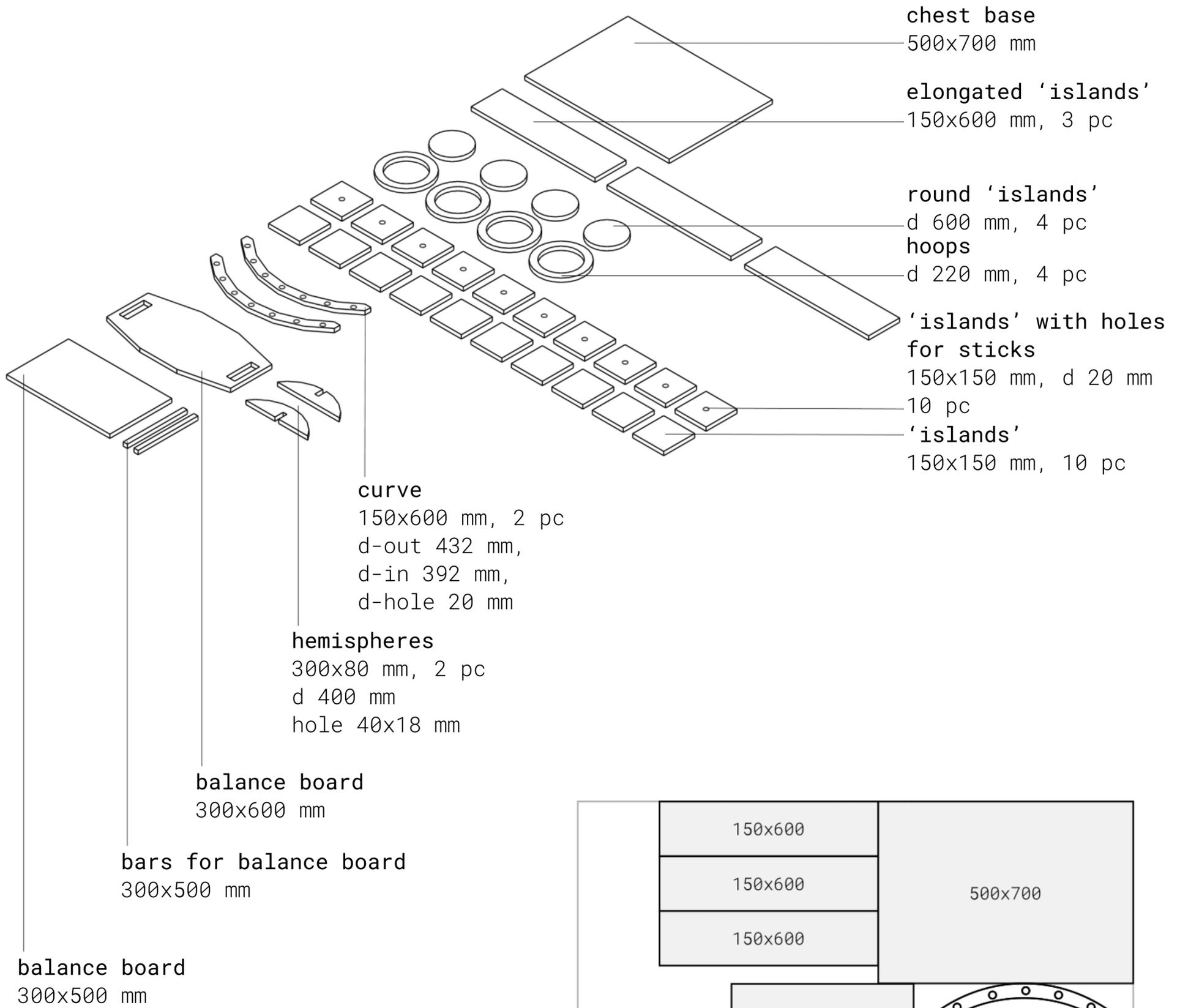

***important**

when applying the pattern, indent between the elements by 3-5 mm

Dimensions.
Other elements.

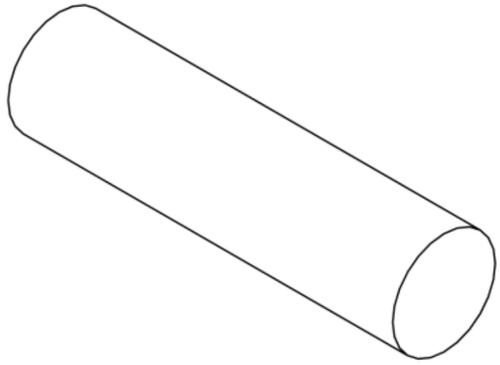

Beam
d 8-12
300 mm

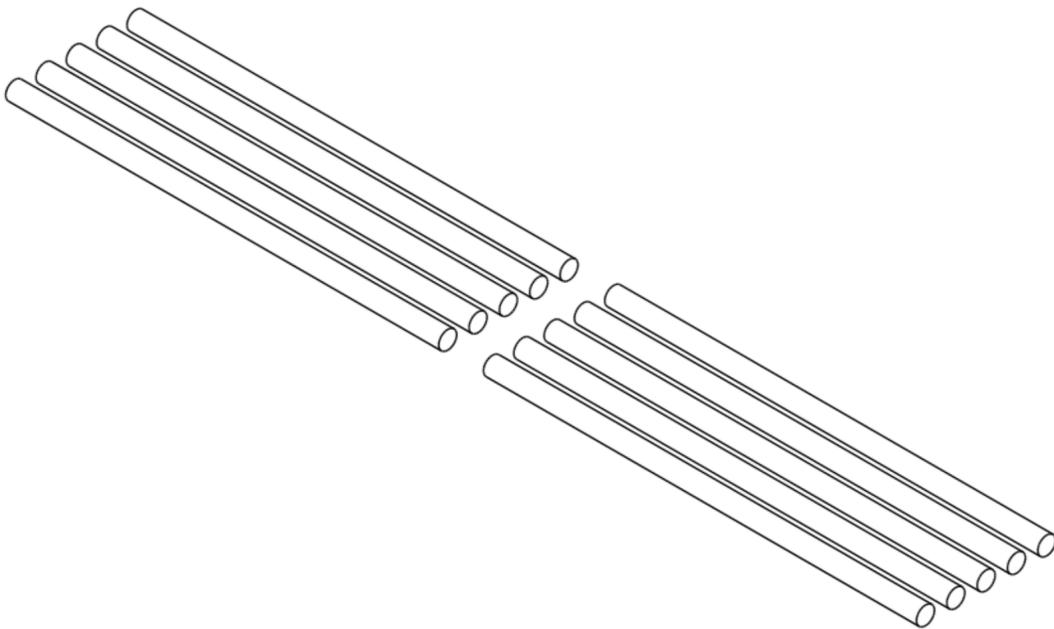

Shovel handles
1200 mm, 5 pc
600 mm, 10 pc

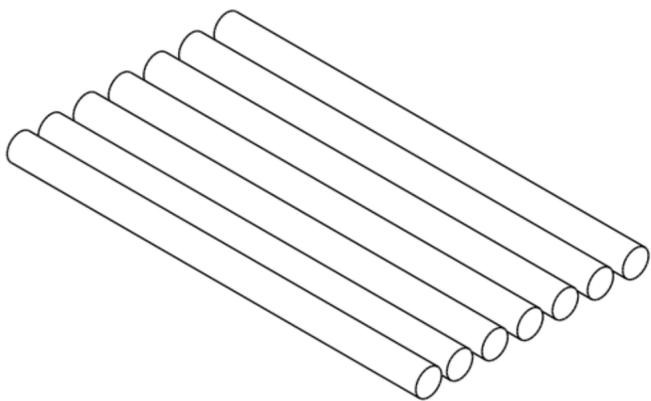

Shovel handles
1200 mm, 3 pc
400 mm, 7 pc