

INSTRUCTION

-TRAPEZOIDAL TABLES AND CHAIRS FOR VARIOUS
FUNCTIONS

WORKED ON THE PROJECT:

AMASH HANUNA-NELLY

MAKSYM YURSHA

LYCHOVA POLINA

LEVCHUK MARIIA

PROSKURA ANNA

A TABLE AND A CHAIR

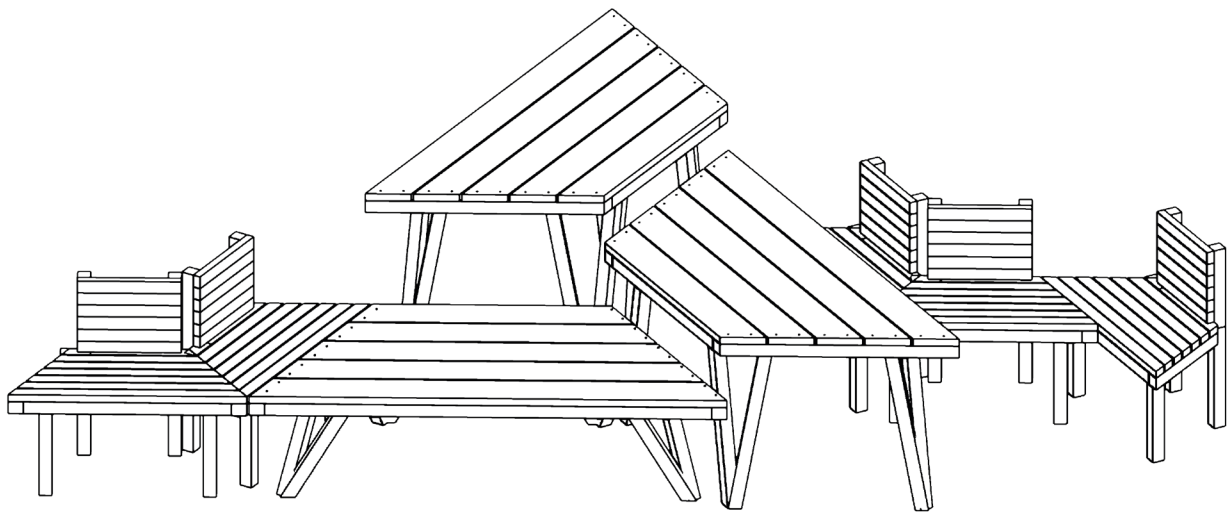

SPECIFICATION



GRINDING MACHINE



BUZZ SAW



TAPE MEASURE



GLOVES FOR WOOD



SCREWDRIVER



LEVEL



SCREW

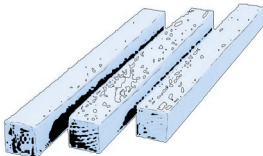

BEAMS (OF DIFFERENT SIZES)



SANDING PAPER



NAILS



WOOD GLUE



HAMMER



BRUSH

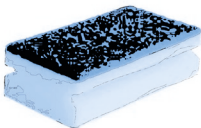

SPONGE



PROTECTIVE GLASSES



DOWEL



CONSTRUCTION PENCIL

CLASSIFICATION:

- A HIGH TABLE
- MEDIUM TABLE
- A LOW TABLE

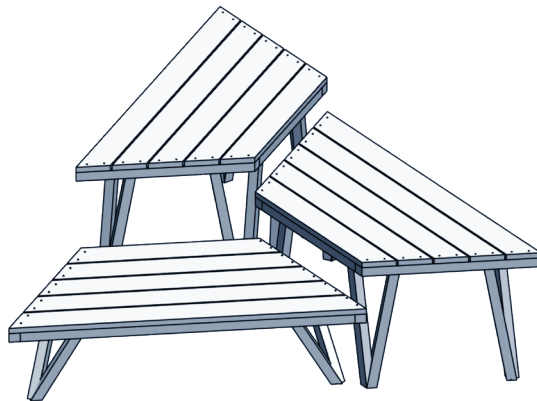

A LOW TABLE

SPECIFICATION

СТІЛ 45CM

	РОЗМІР ММ	КІЛЬКІСТЬ
БРУС	50x50x4000	3
ДОШКА	30x50x4000	2
ЦВЯХИ	2x50	20
ГВИНТИ	5x80	24
САМОРИЗИ	3,5x45	16
З'ЄДНУВАЛЬНІ ПЛАСТИНИ	2x30x35	4

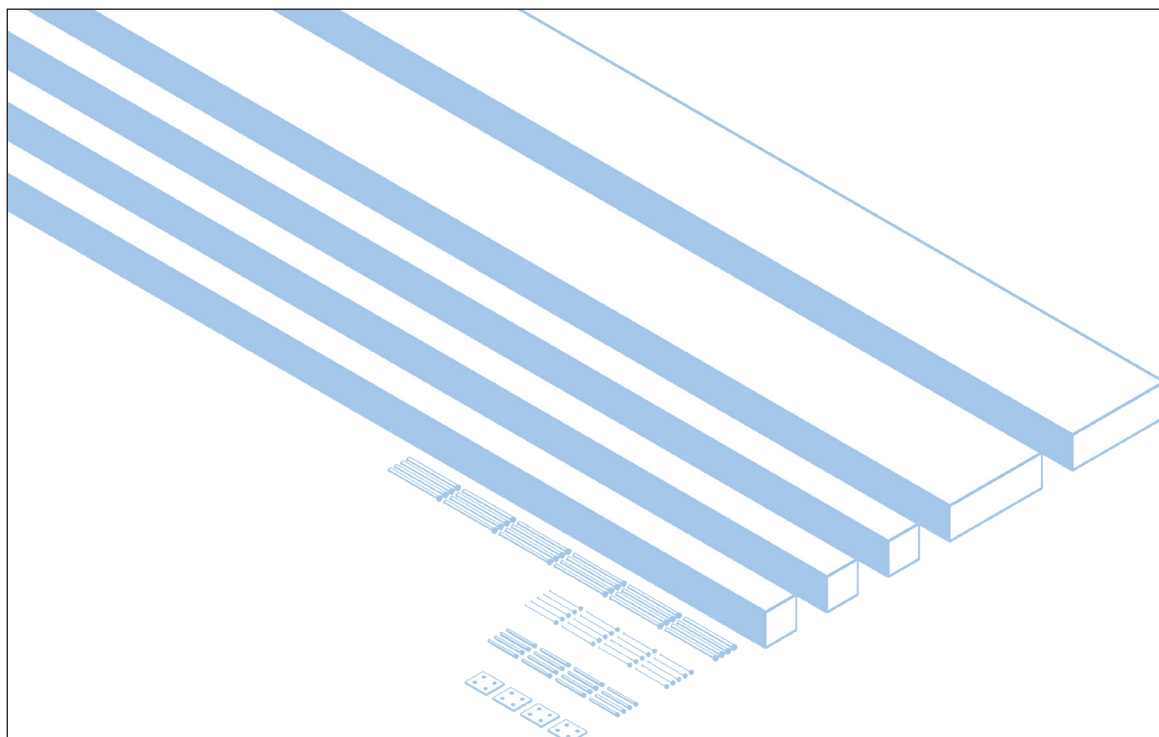

A LOW TABLE

CUTTING BEAMS

- 90°
- 60°
- 30°

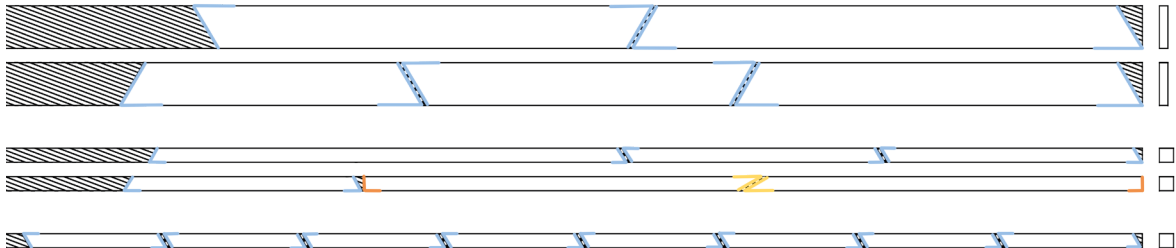

THE LENGTH IS ALWAYS MEASURED ON THE LONGER SIDE

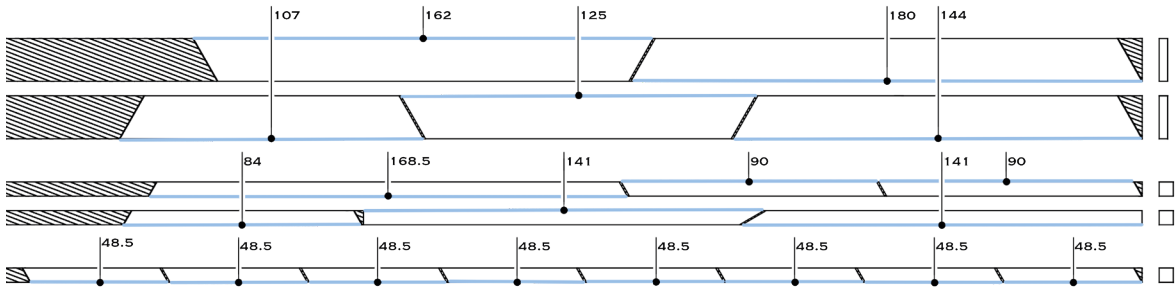
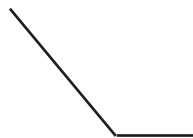
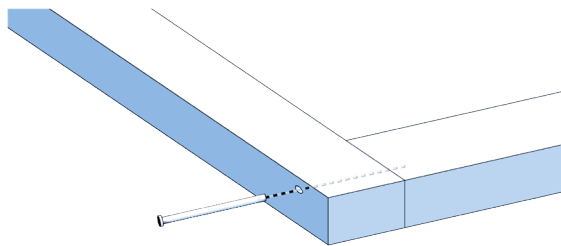
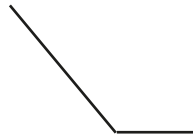
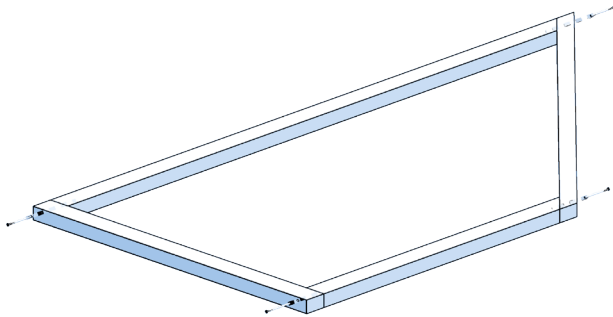
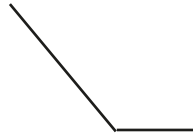
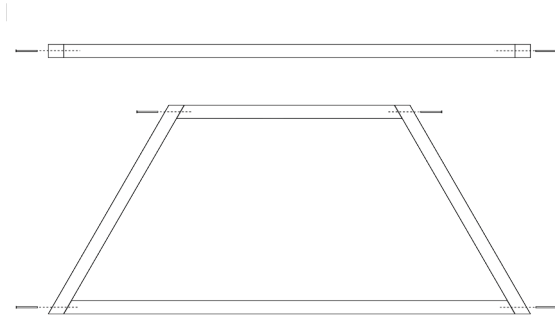
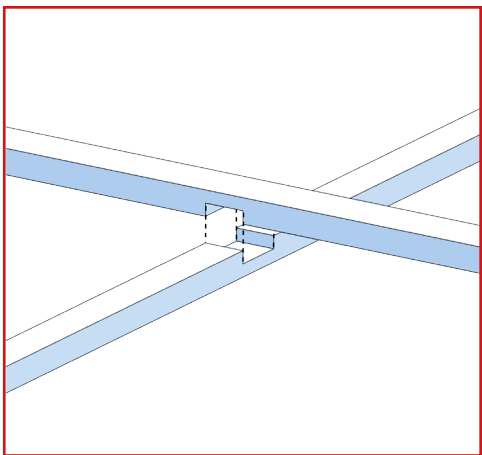
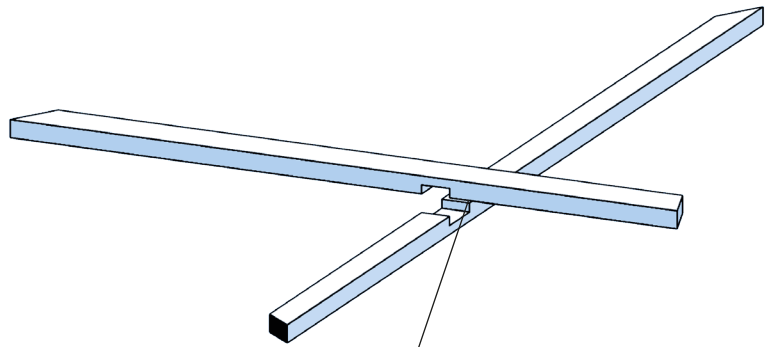
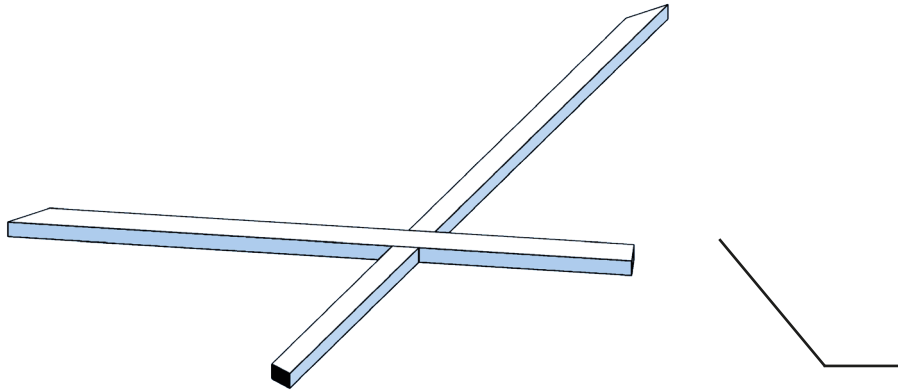

TABLE FRAME

FOR ALL TYPES OF TABLES IS THE SAME





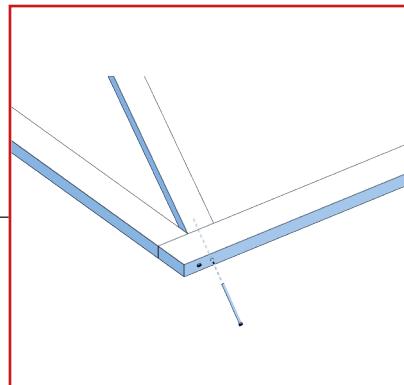
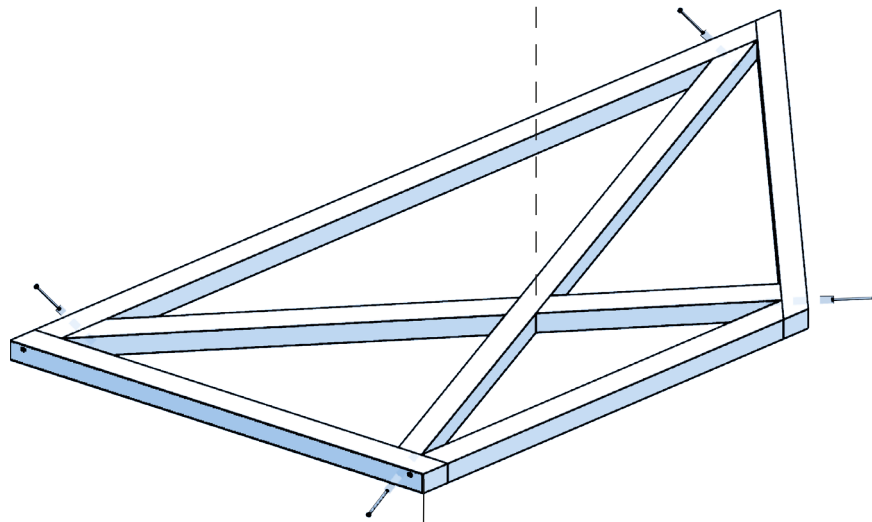
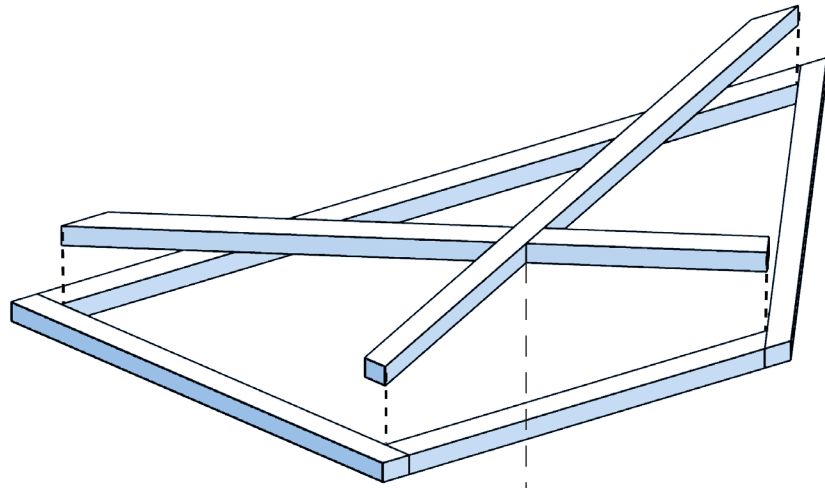

TABLE TOP

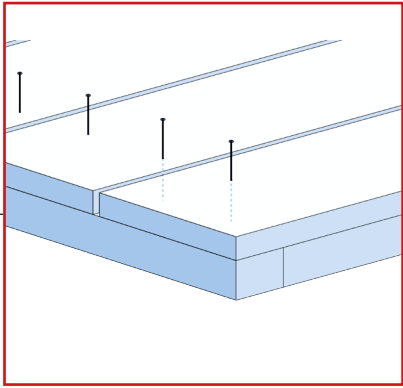
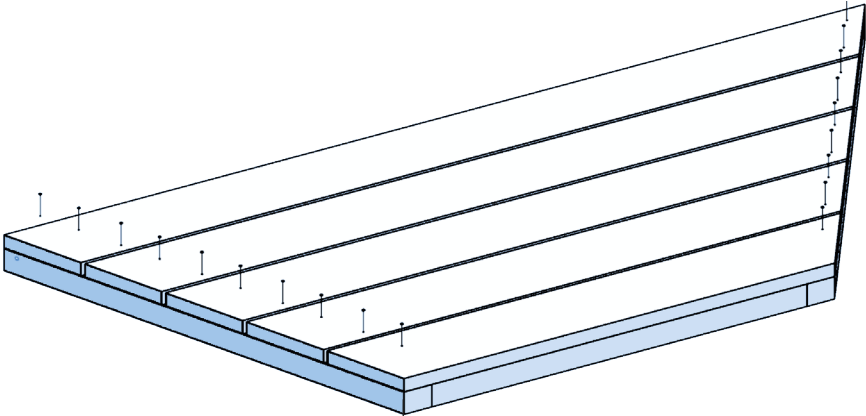
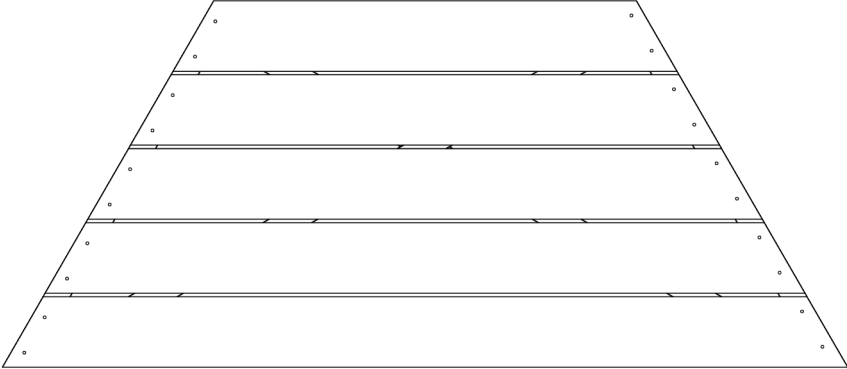
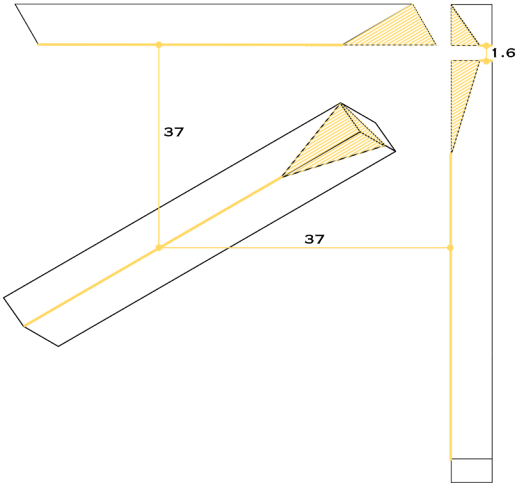

TABLE LEGS AND THEIR ATTACHMENTS

CUTTING TABLE LEGS

VERSION 1



VERSION 2

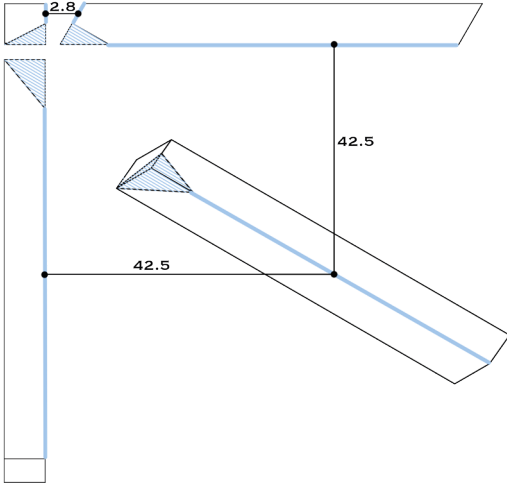

THE LENGTHS ARE MEASURED ON BOTH SIDES AND 2 POINTS + ONE POINT IN THE VERY CORNER ARE PLACED. AND THEN THESE 3 POINTS ARE CONNECTED.

CONNECTING THE LEGS

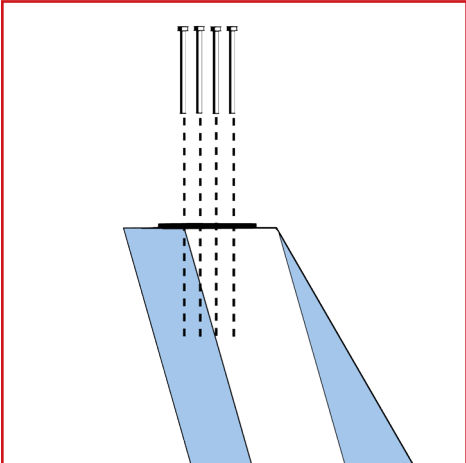
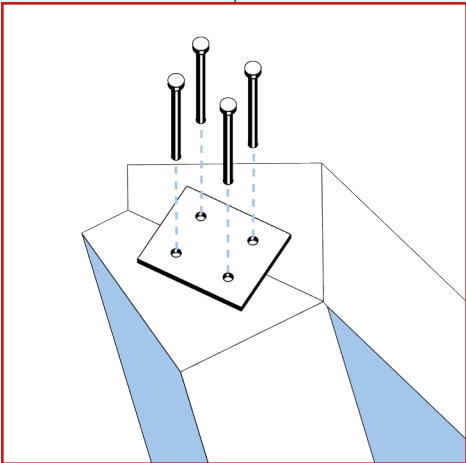
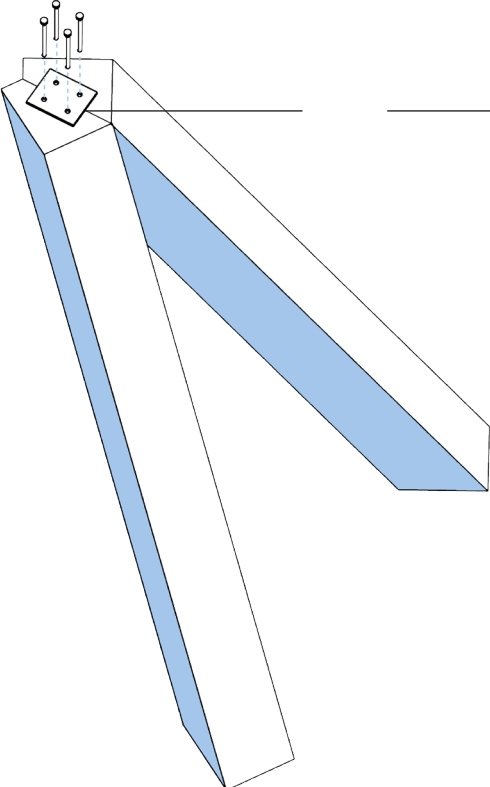

FASTENING THE LEGS TO THE FRAME

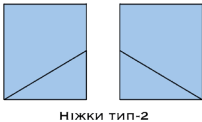
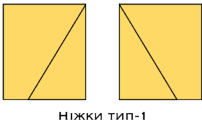
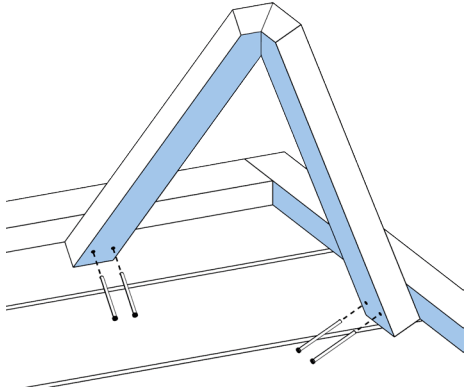

THERE MUST BE TWO PAIRS OF SYMMETRICAL LEGS OF BOTH TYPES

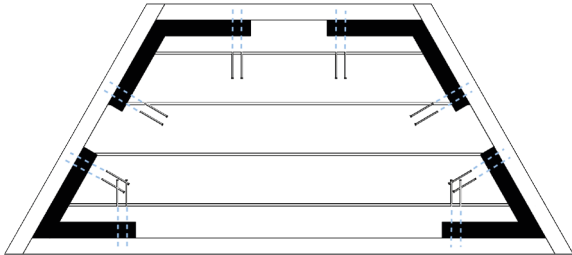
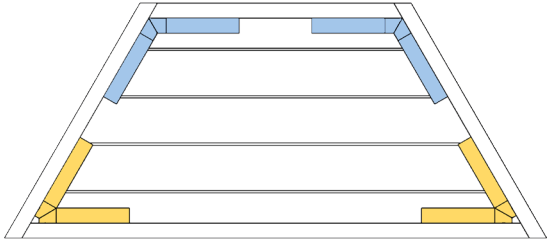

MEDIUM TABLE

SPECIFICATION

СТІЛ 75CM

	РОЗМІР ММ	КІЛЬКІСТЬ
БРУС	50x50x4000	4
ДОШКА	30x50x4000	2
ЦВЯХИ	2x50	20
ГВИНТИ	5x80	24
САМОРИЗИ	3,5x45	16
З'ЄДНУВАЛЬНІ ПЛАСТИНИ	2x30x35	4

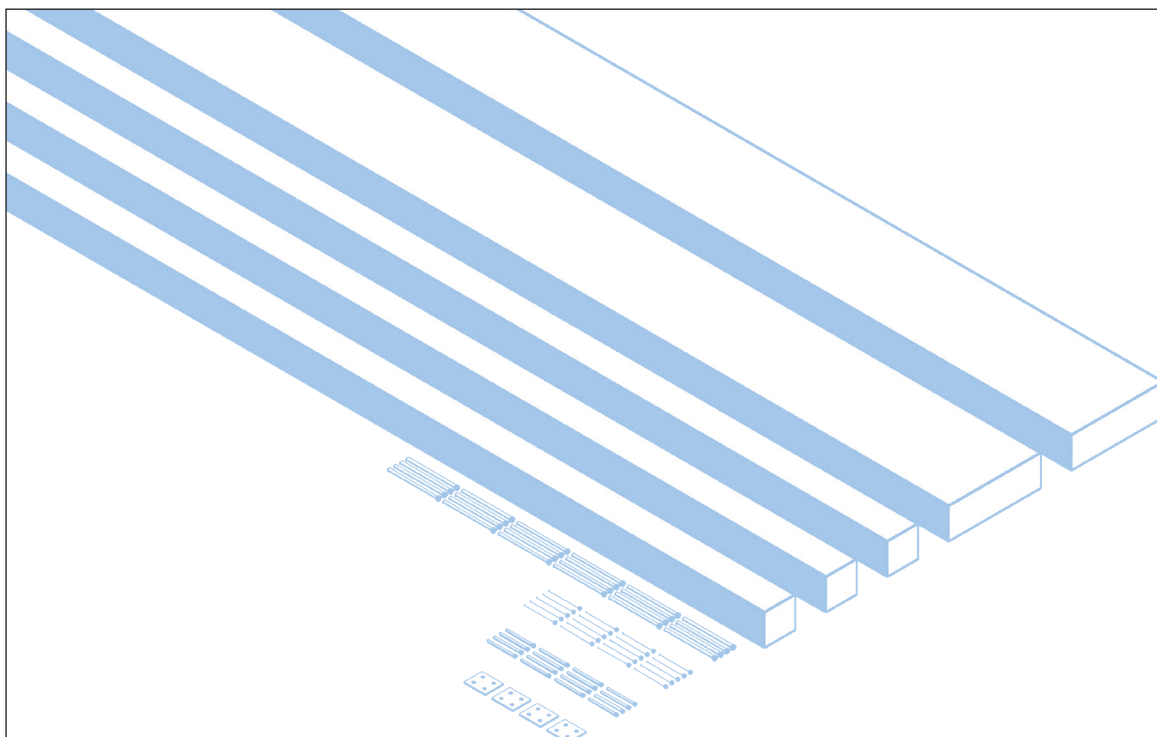

MEDIUM TABLE

CUTTING BEAMS

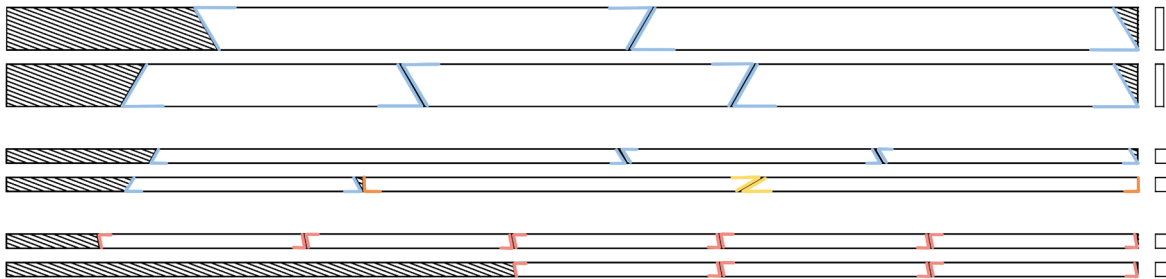
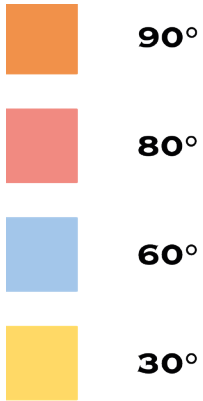

THE LENGTH IS ALWAYS MEASURED ON THE LONGER SIDE

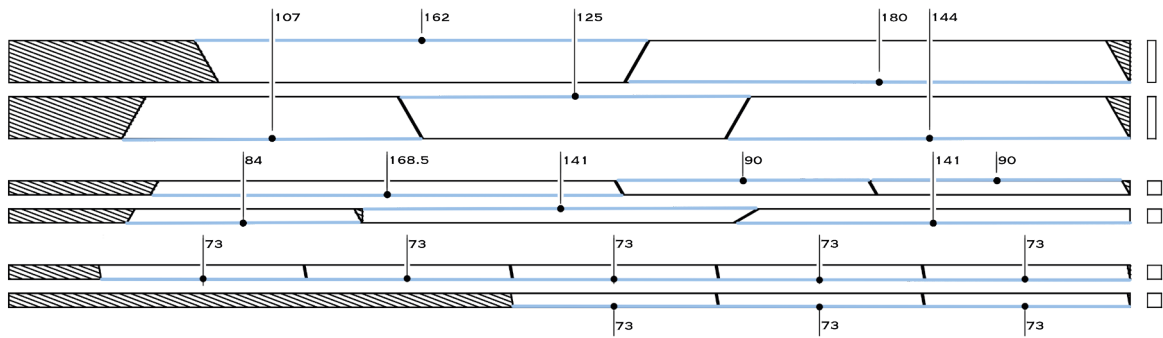
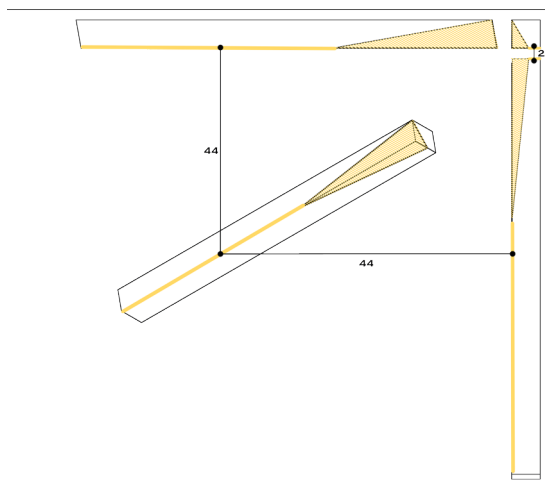

TABLE LEGS AND THEIR ATTACHMENTS

CUTTING TABLE LEGS

BAPIAHT 1



BAPIAHT 2

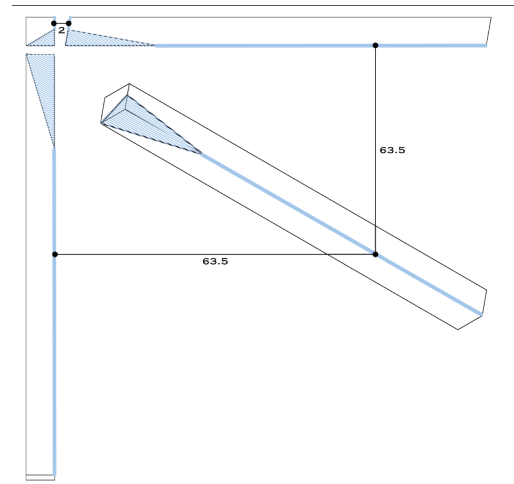

THE LENGTHS ARE MEASURED
ON BOTH SIDES AND 2 POINTS +
ONE POINT IN THE VERY CORNER
ARE PLACED. AND THEN THESE
3 POINTS ARE CONNECTED.

CONNECTING THE LEGS

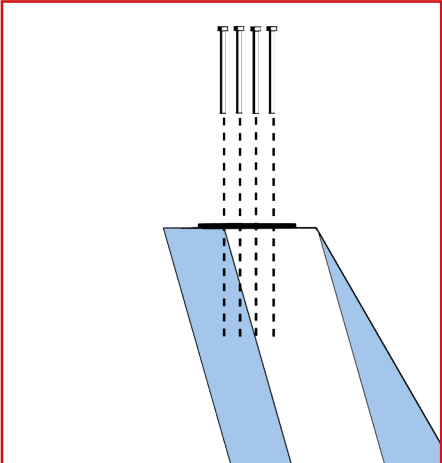
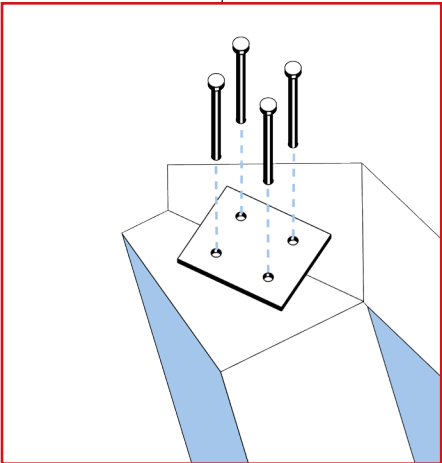
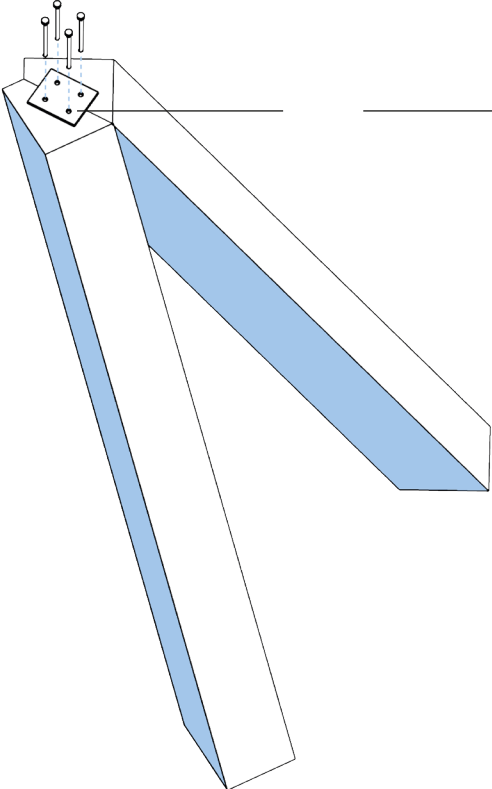

FASTENING THE LEGS TO THE FRAME

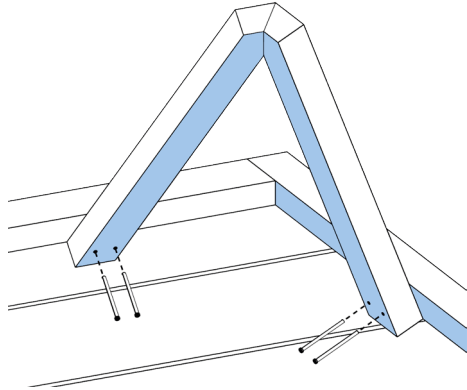

— THERE MUST BE TWO PAIRS OF SYMMETRICAL LEGS OF BOTH TYPES

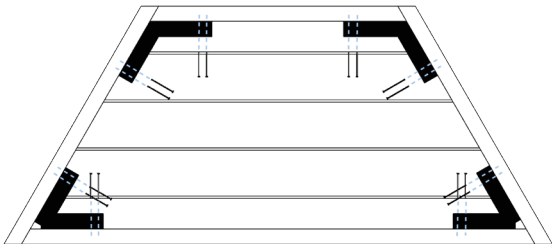
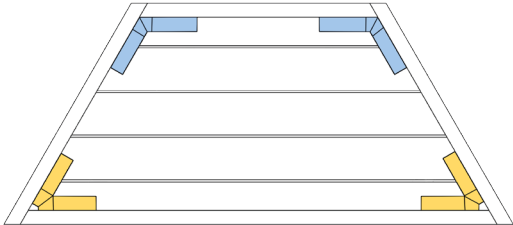

A HIGH TABLE

SPECIFICATION

СТІЛ 90СМ

	РОЗМІР ММ	КІЛЬКІСТЬ
БРУС	50x50x4000	4
ДОШКА	30x50x4000	2
ЦВЯХИ	2x50	20
ГВИНТИ	5x80	24
САМОРИЗИ	3,5x45	16
З'ЄДНУВАЛЬНІ ПЛАСТИНИ	2x30x35	4

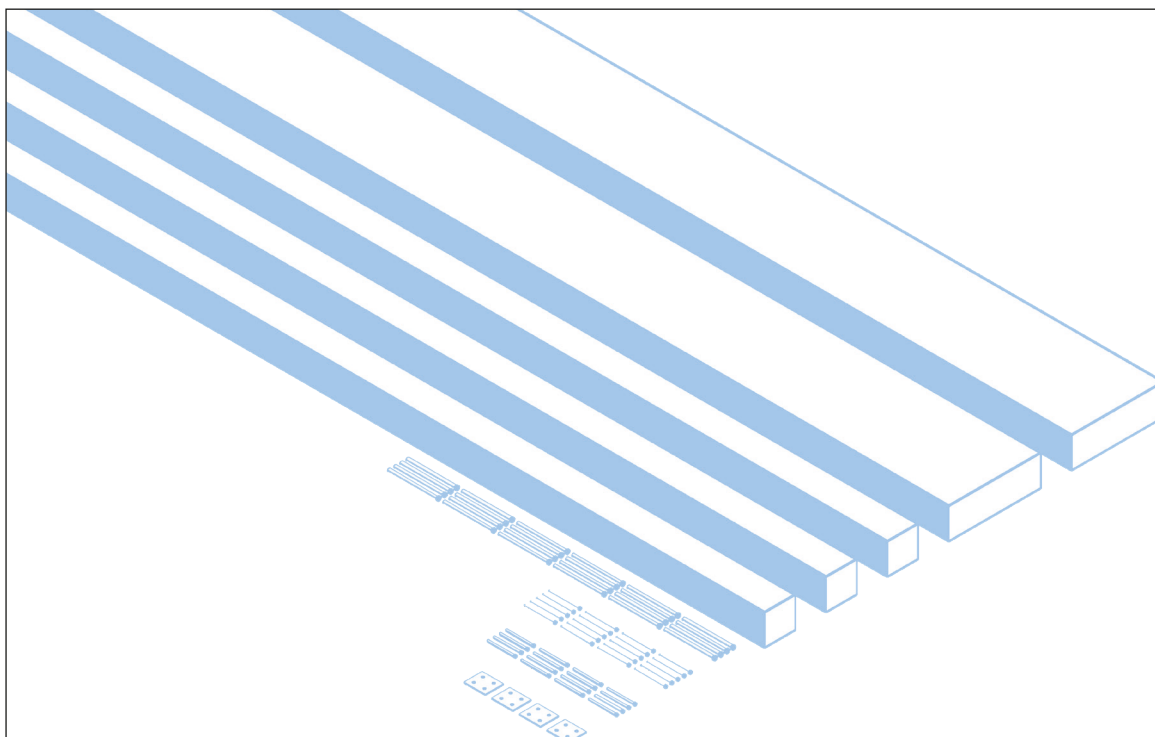

A HIGH TABLE

CUTTING BEAMS

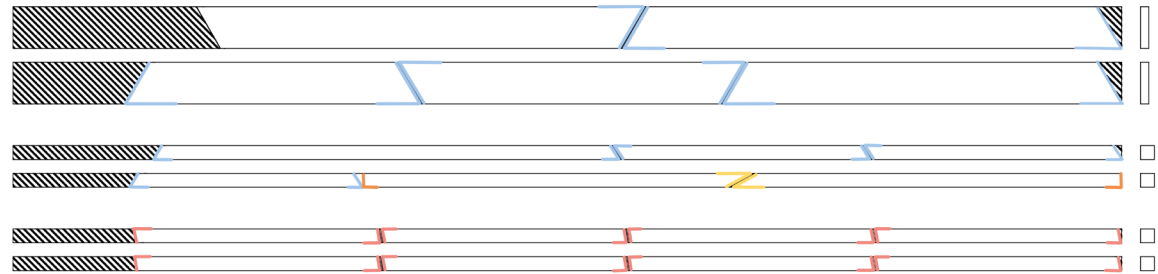
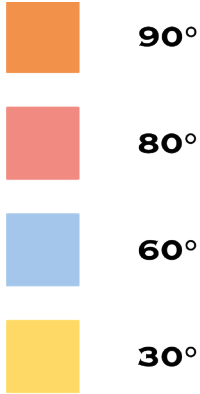

THE LENGTH IS ALWAYS MEASURED ON THE LONGER SIDE

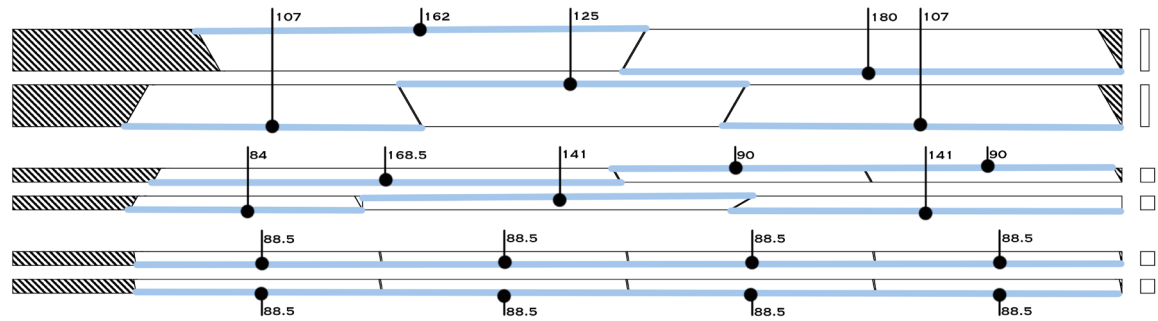
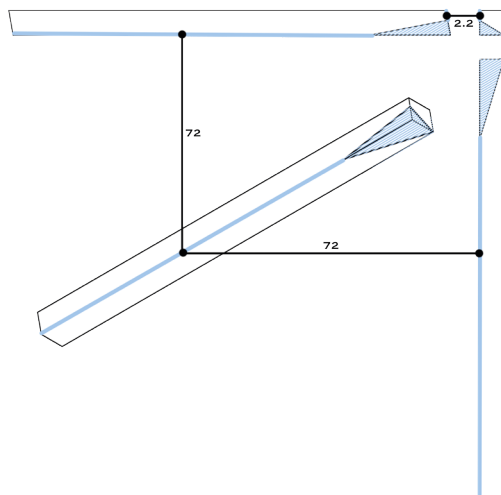

TABLE LEGS AND THEIR ATTACHMENTS

CUTTING TABLE LEGS

BAPIAHT 1



BAPIAHT 2

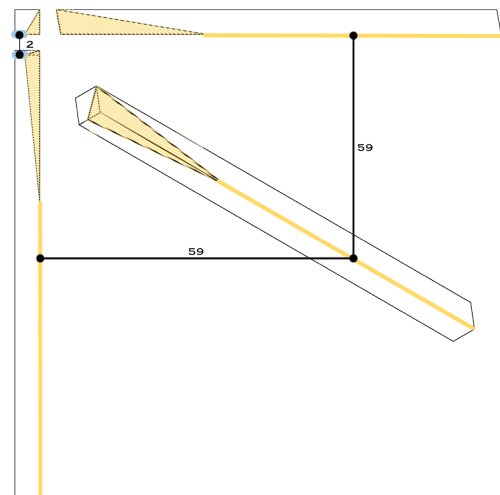

THE LENGTHS ARE MEASURED
ON BOTH SIDES AND 2 POINTS +
ONE POINT IN THE VERY CORNER
ARE PLACED. AND THEN THESE
3 POINTS ARE CONNECTED.

CONNECTING THE LEGS

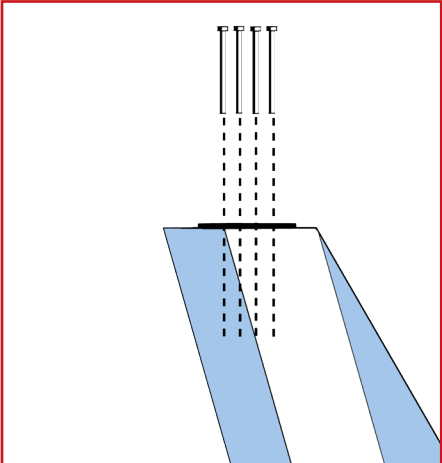
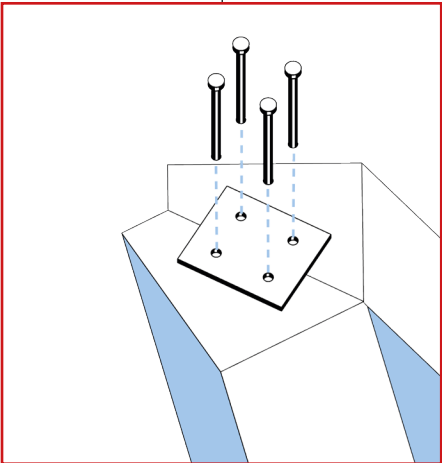
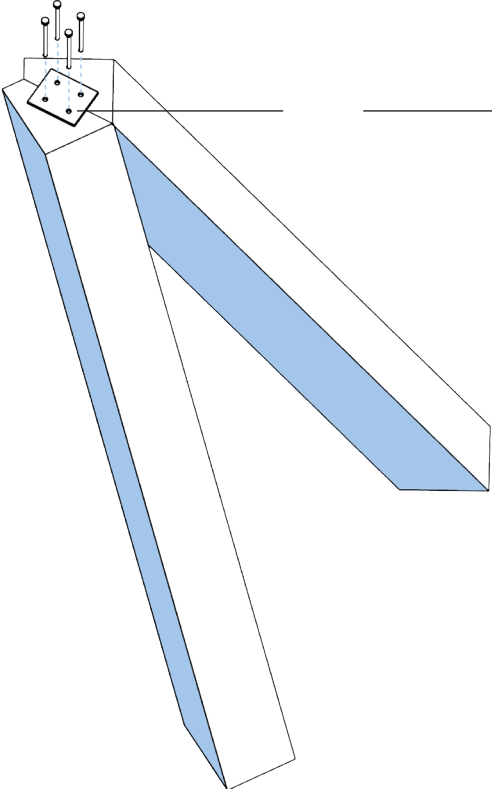

FASTENING THE LEGS TO THE FRAME

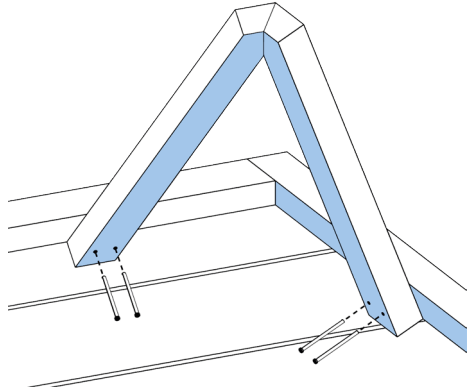

— THERE MUST BE TWO PAIRS OF SYMMETRICAL LEGS OF BOTH TYPES

