



PLATFORM

a set of outdoor modular furniture



Team:
Roksana Less
Denys Tokar
Matvii Masliukov

Tutors:
Mariia Tselik
Mykhailo Shevchenko
Anastasiia Kondratieva

selected configurations:

1

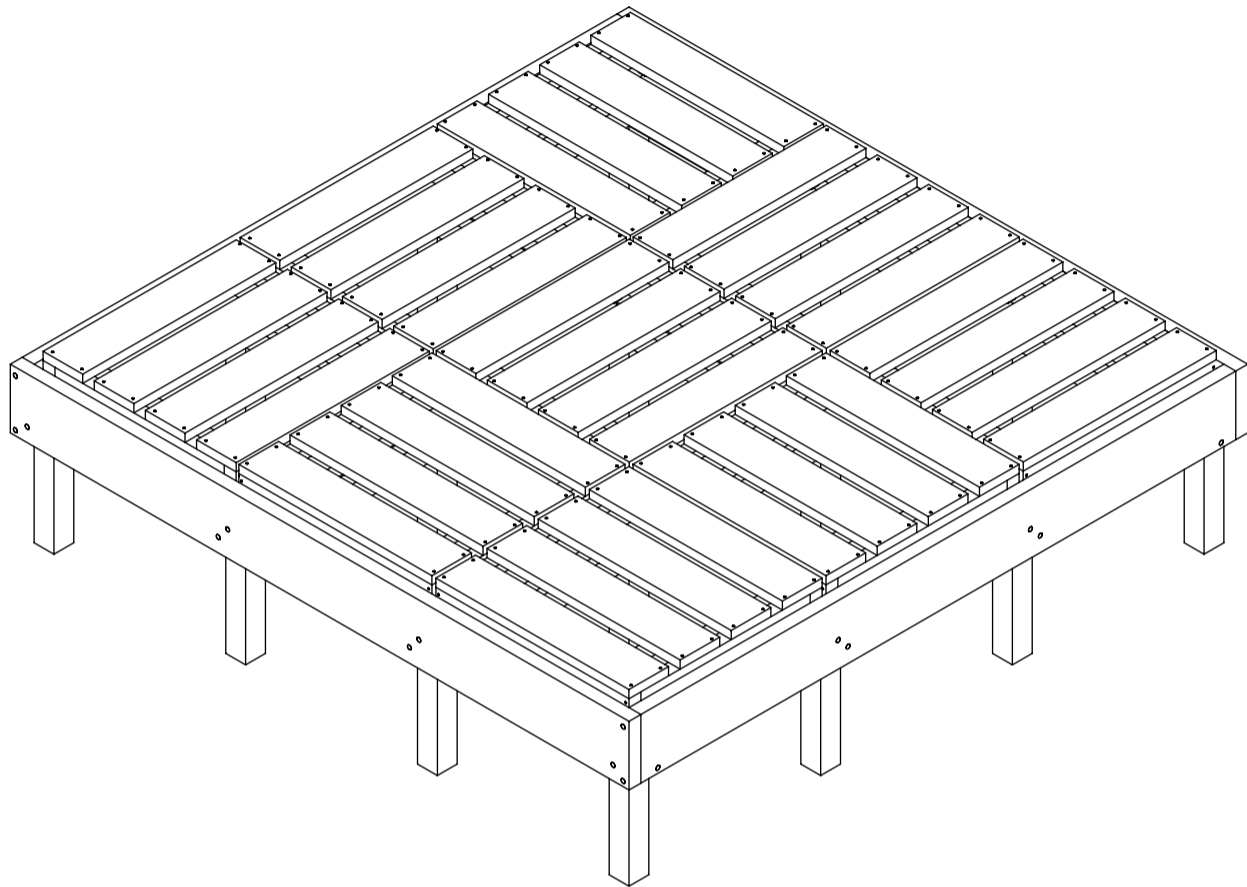

“too easy”

2

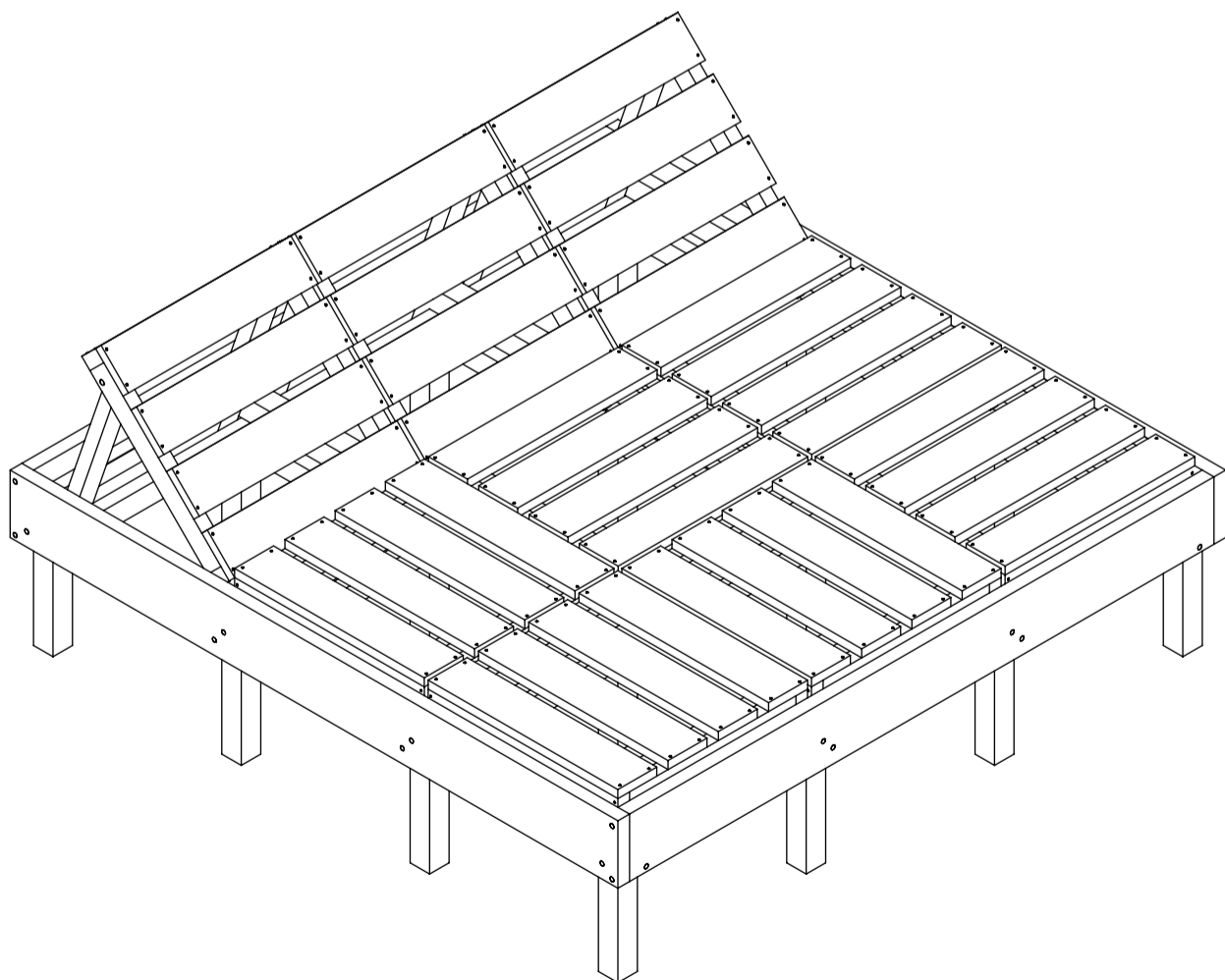

“outlook bench”

3

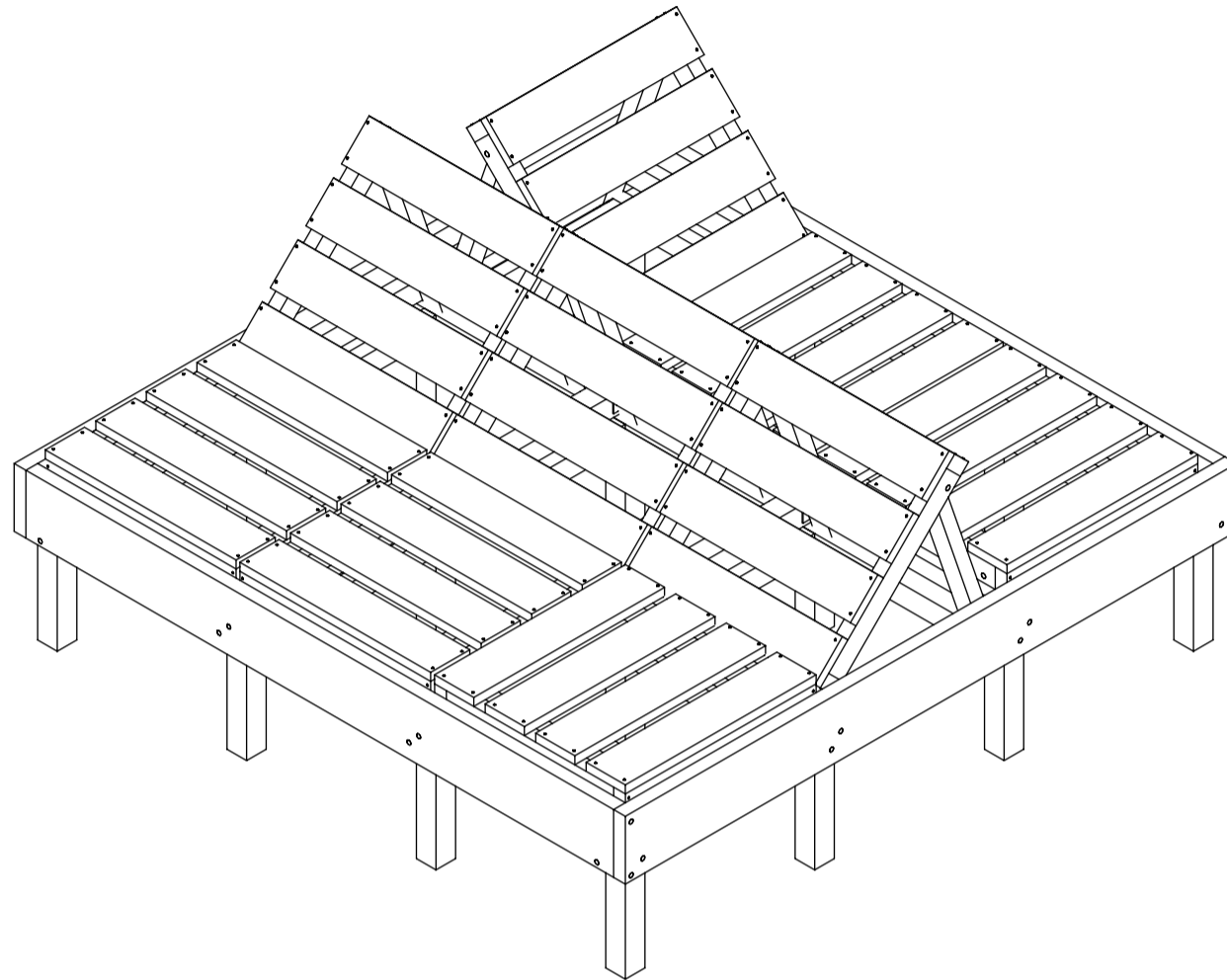

“one vs.
the world”

4

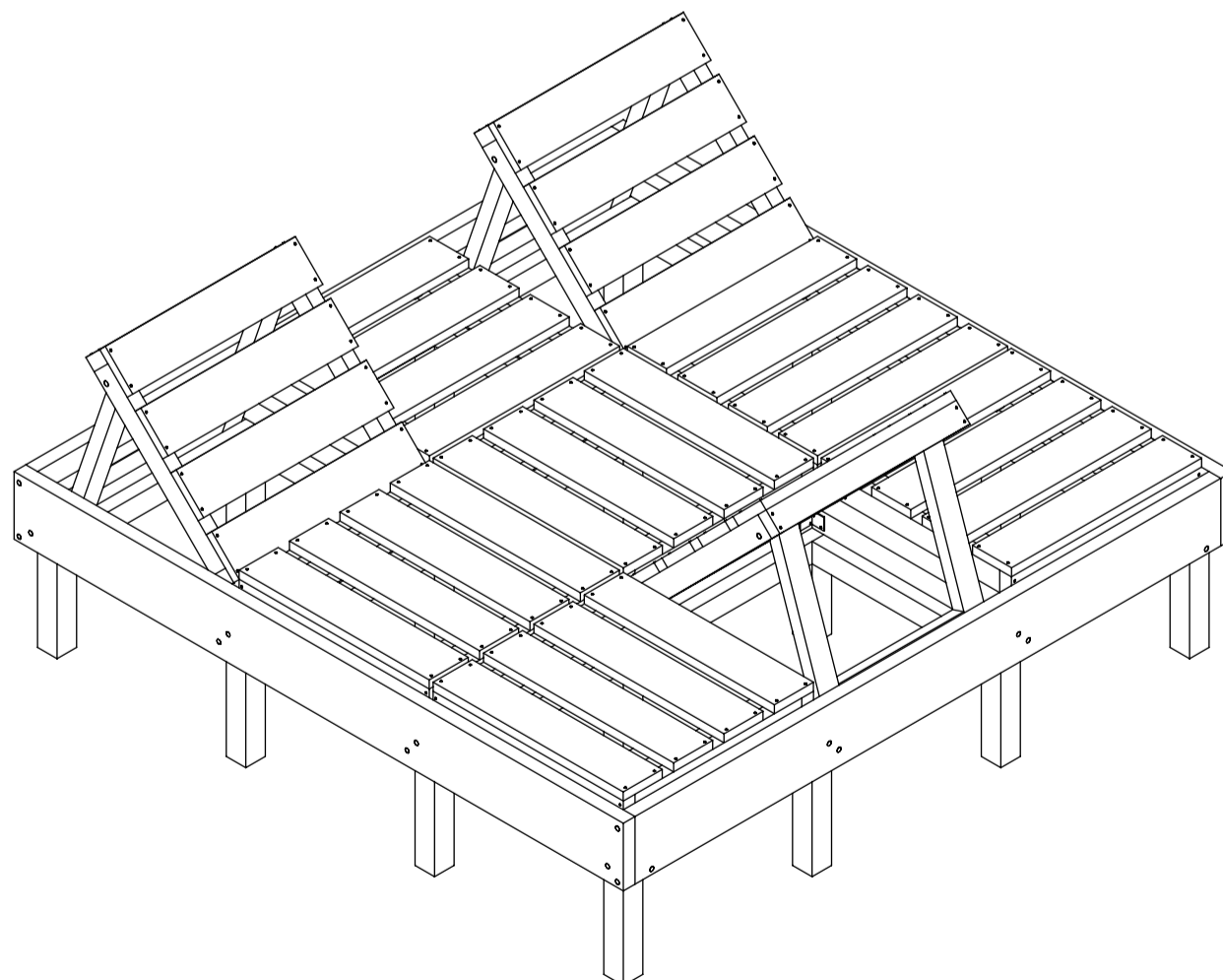

“zigzag”

timber:

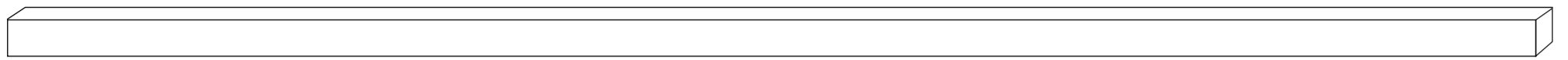

beam 50x50x1440

2 pcs.

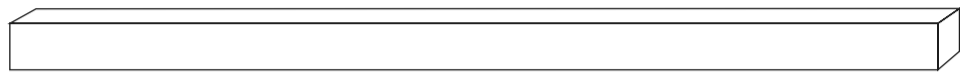

beam 50x50x453

4 pcs.

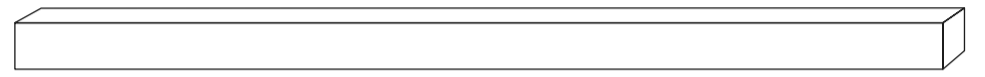

beam 50x50x433

2 pcs.

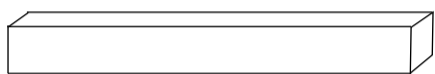

beam 50x50x290 12 pcs.

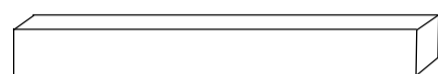

beam 50x30x373 18 pcs.

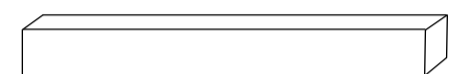

beam 50x30x320 9 pcs.



beam 50x30x1440

2 pcs.

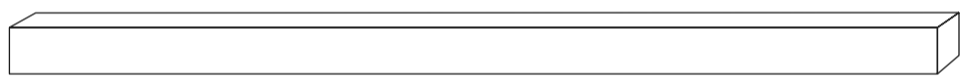

beam 50x30x487

18 pcs.

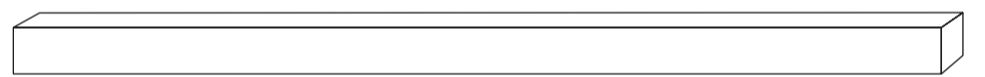

beam 50x30x427

18 pcs.



beam 50x30x397

18 pcs.

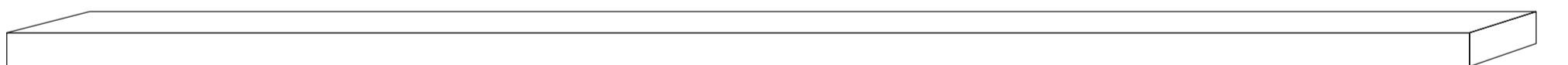

plank 30x150x1560

2 pcs.

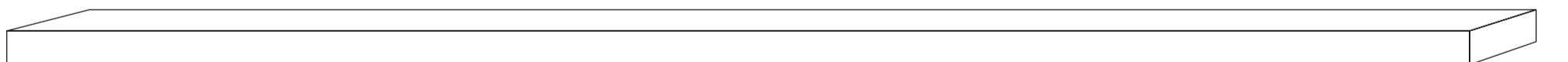

plank 30x150x1500

2 pcs.

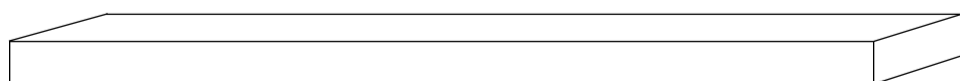

plank 20x100x490

36 pcs.

fasteners+:

DIN571 screw 6,0x60 - 168 pcs.

DIN931 bolt M8x100 8.8 - 18 pcs.

DIN125-2 washer 8 mm - 54 pcs.

DIN6926 nut M8 8 mm - 18 pcs.

wood screw 3,5x45 mm - 208 pcs.

wood screw 3,5x100 mm - 108 pcs.

perforated equilateral corner 40x40x20 - 16 pcs.

bitumen-rubber mastic

masking tape

instruments:

screwdriver (better 2 or 3), milling cutter, wood drill bit,
forstner bit - 15 mm

screwdriver bits: hexagonal, cross

other: brush, sponge

templates

to be made out of plywood,
holes of arbitrary diameter
for marking with a pencil and/or drilling

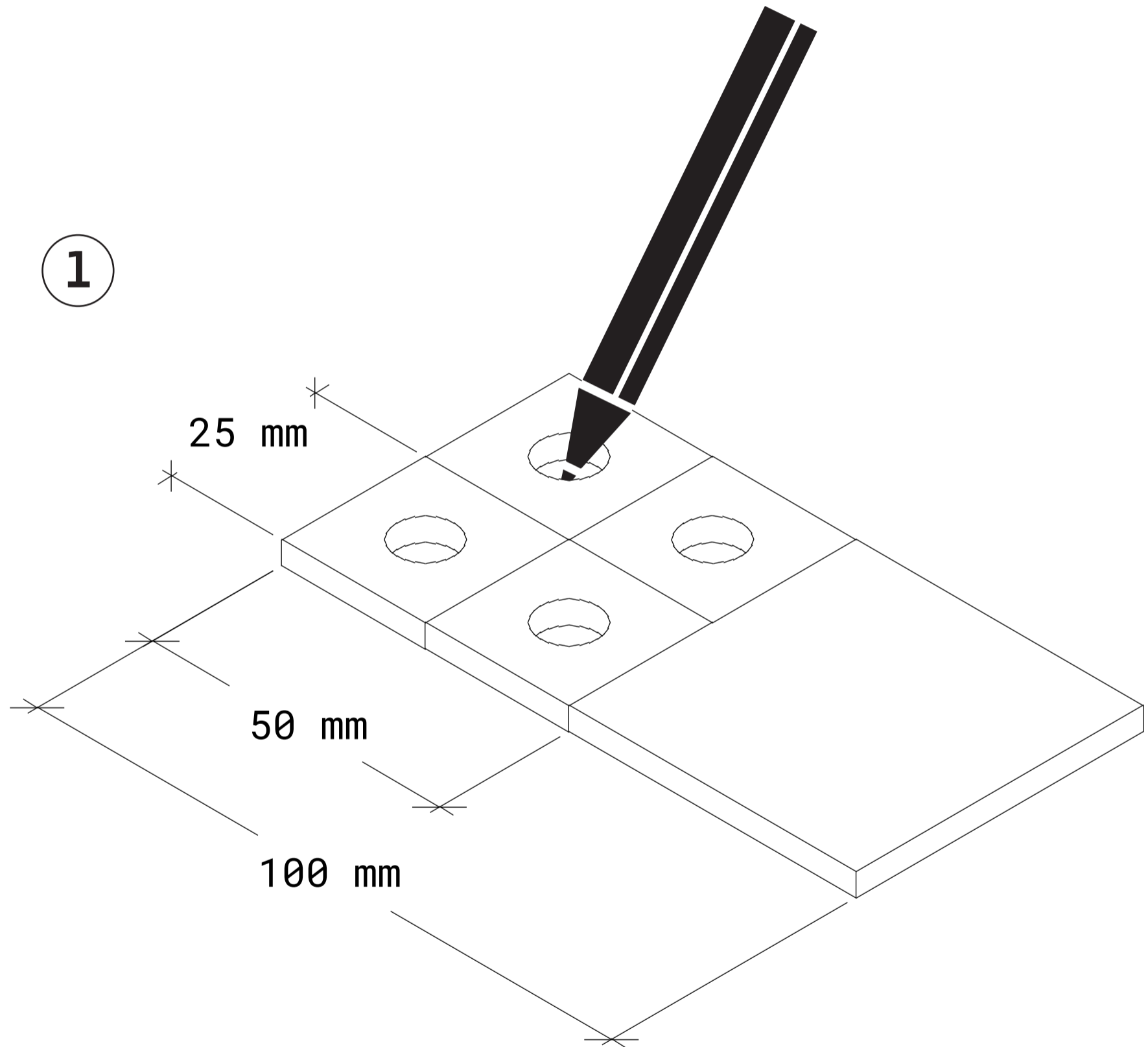

* to be used in the frame and contour assembly

2

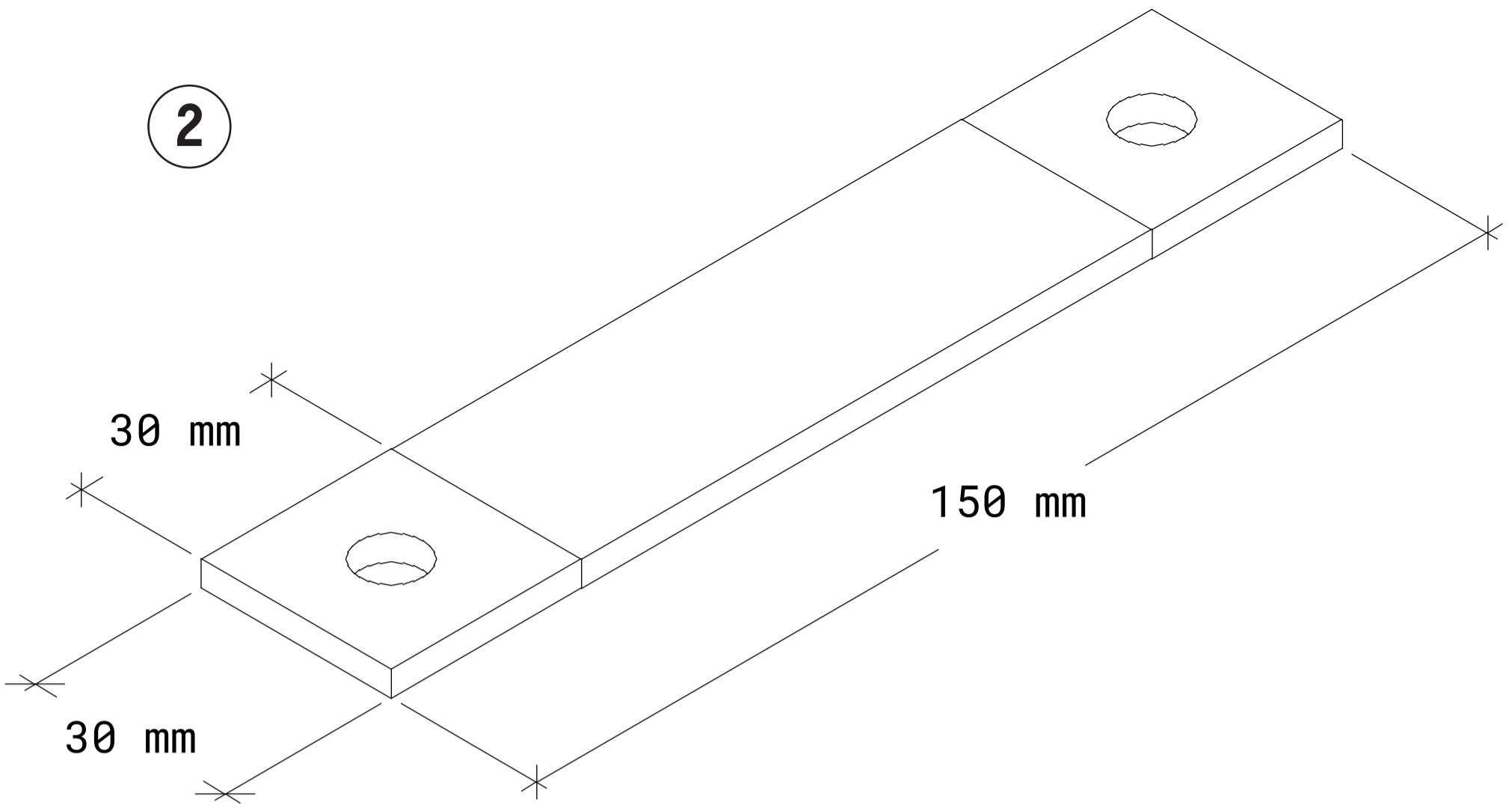

* to be used in the contour assembly

3

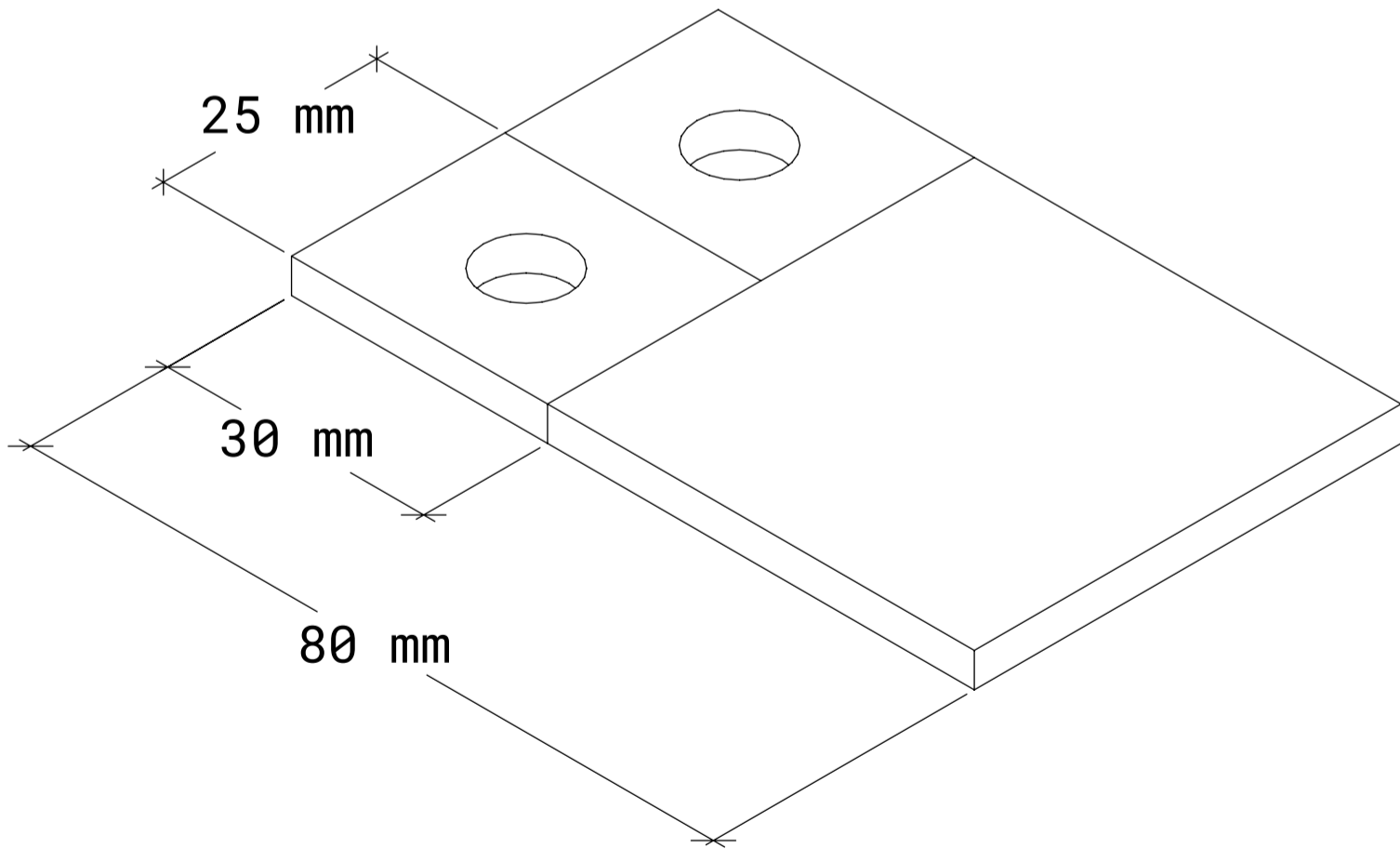

* to be used in the frame and module assembly

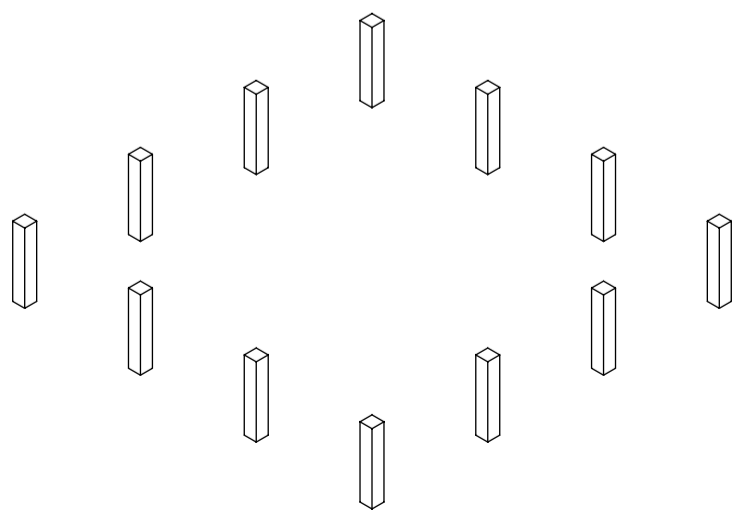
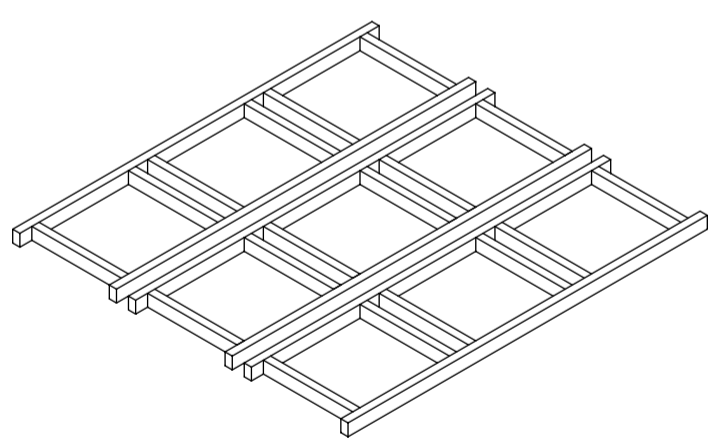
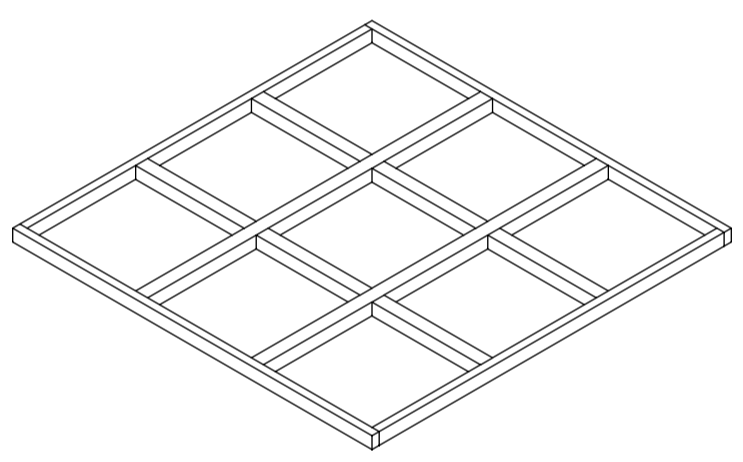
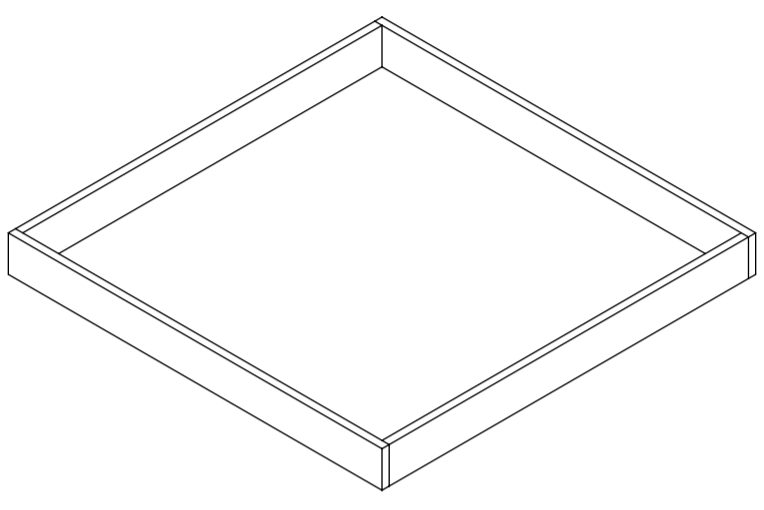
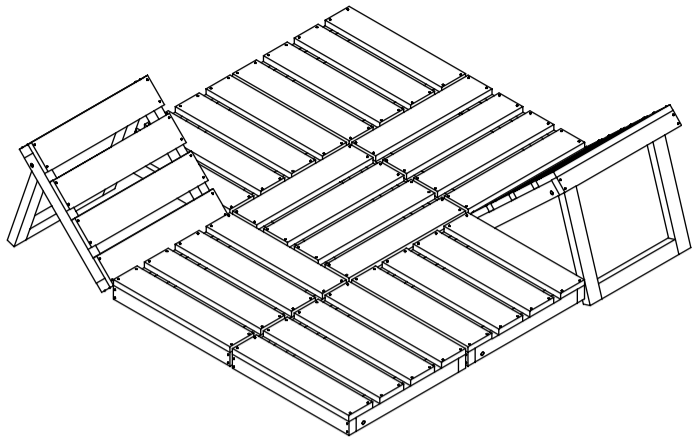

modules

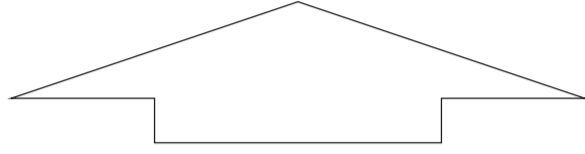

contour

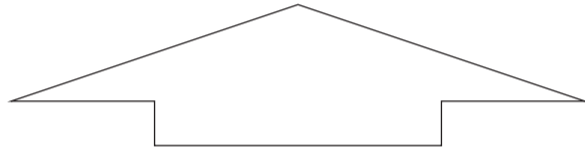

**upper
frame**

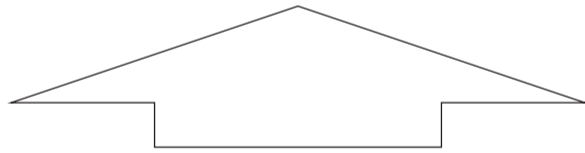

**lower
frame**

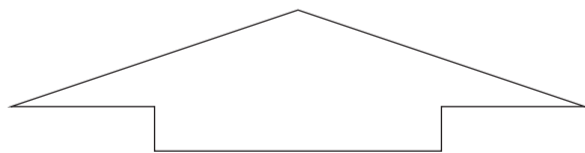

legs

Legs

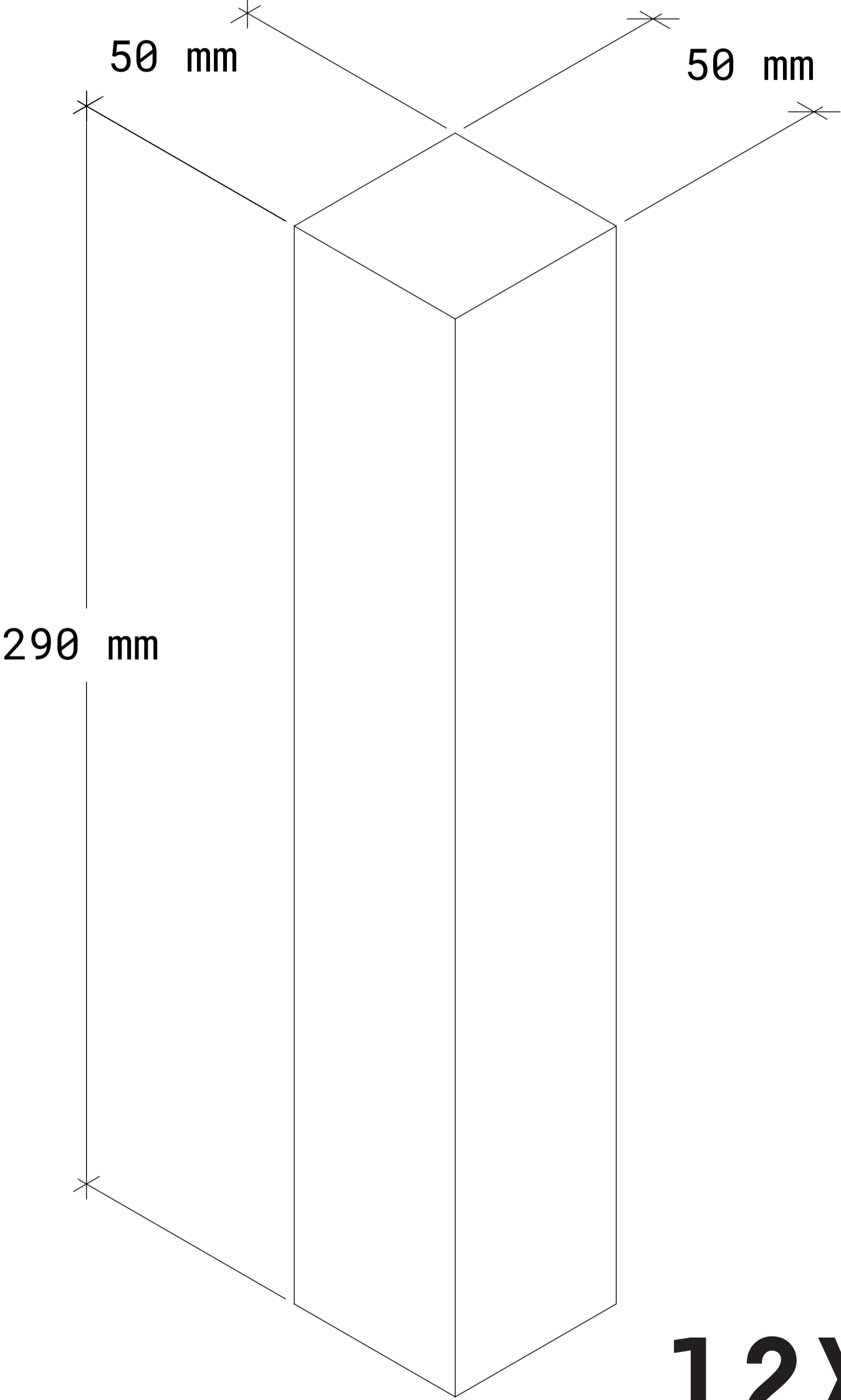

12X

**thoroughly cover each leg with bitumen,
let it dry for one day**

* it is better to do it after
the platform is fully assembled

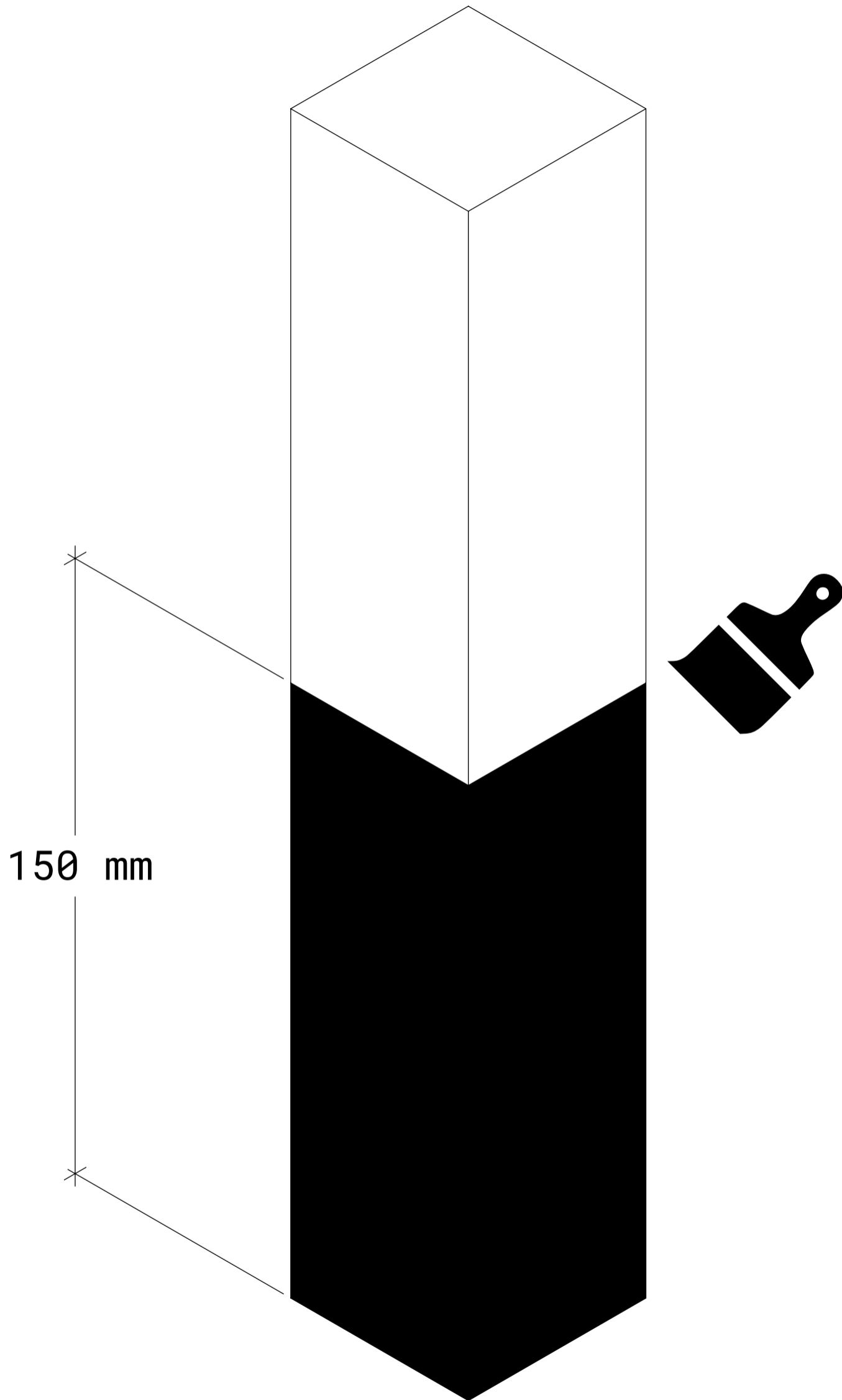

Lower frame

what you will need:

screws: DIN571 screw 6,0x60 - 104 pcs.

timber: legs - 12 pcs.,

beam 30x50x1500 - 6 pcs.,

beam 30x50x373,3 - 18 pcs.

other: template #1, #3, instruments + forstner bit

1 ladder with legs - 2 pcs.

2 ladder - 1 pc.

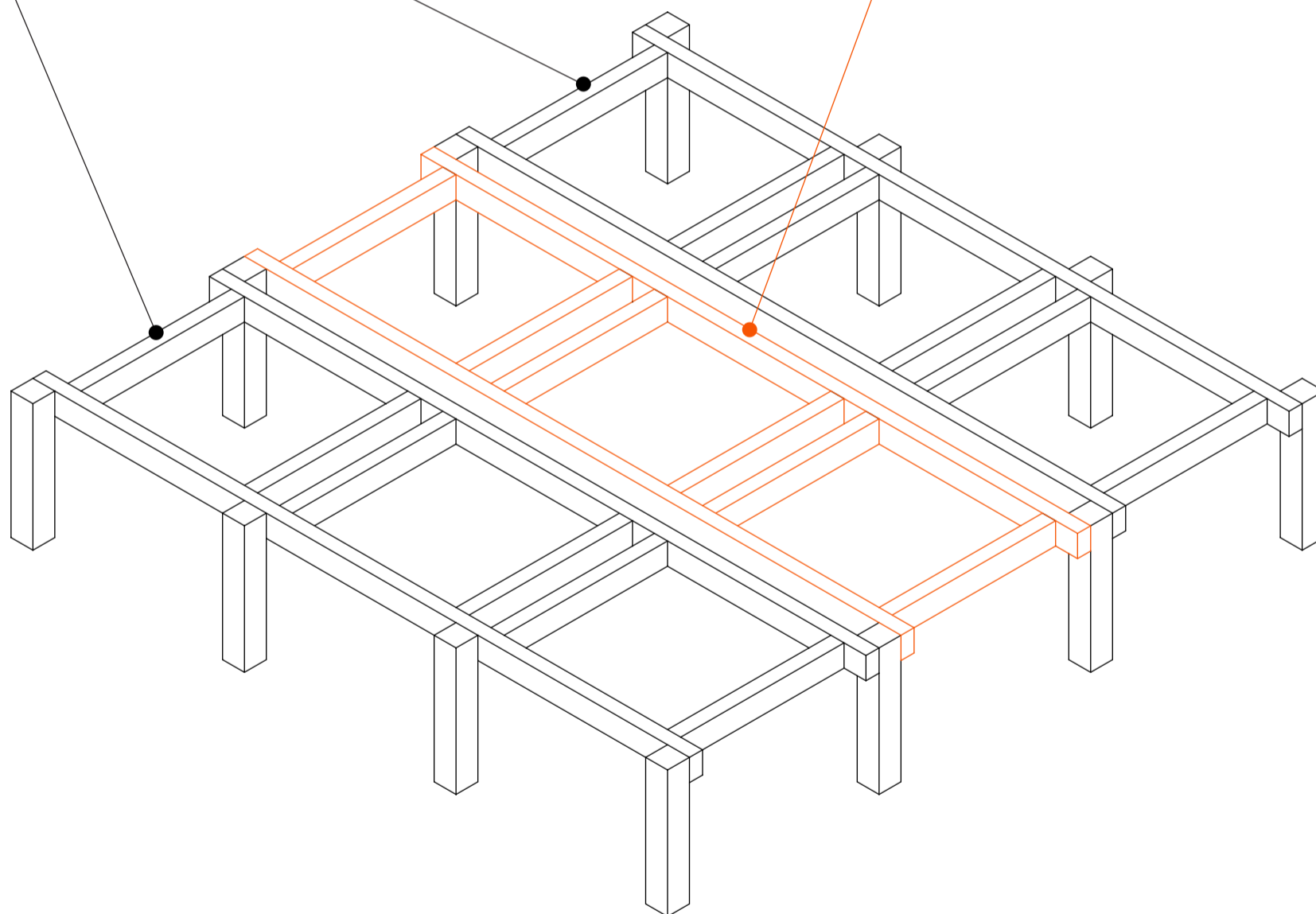

assembly algorithm:

mark the holes with a pencil using a template,

drill a round hole with a forstner bit,

drill with a regular drill, connect with a screw

1

ladder with legs - 2 pcs.

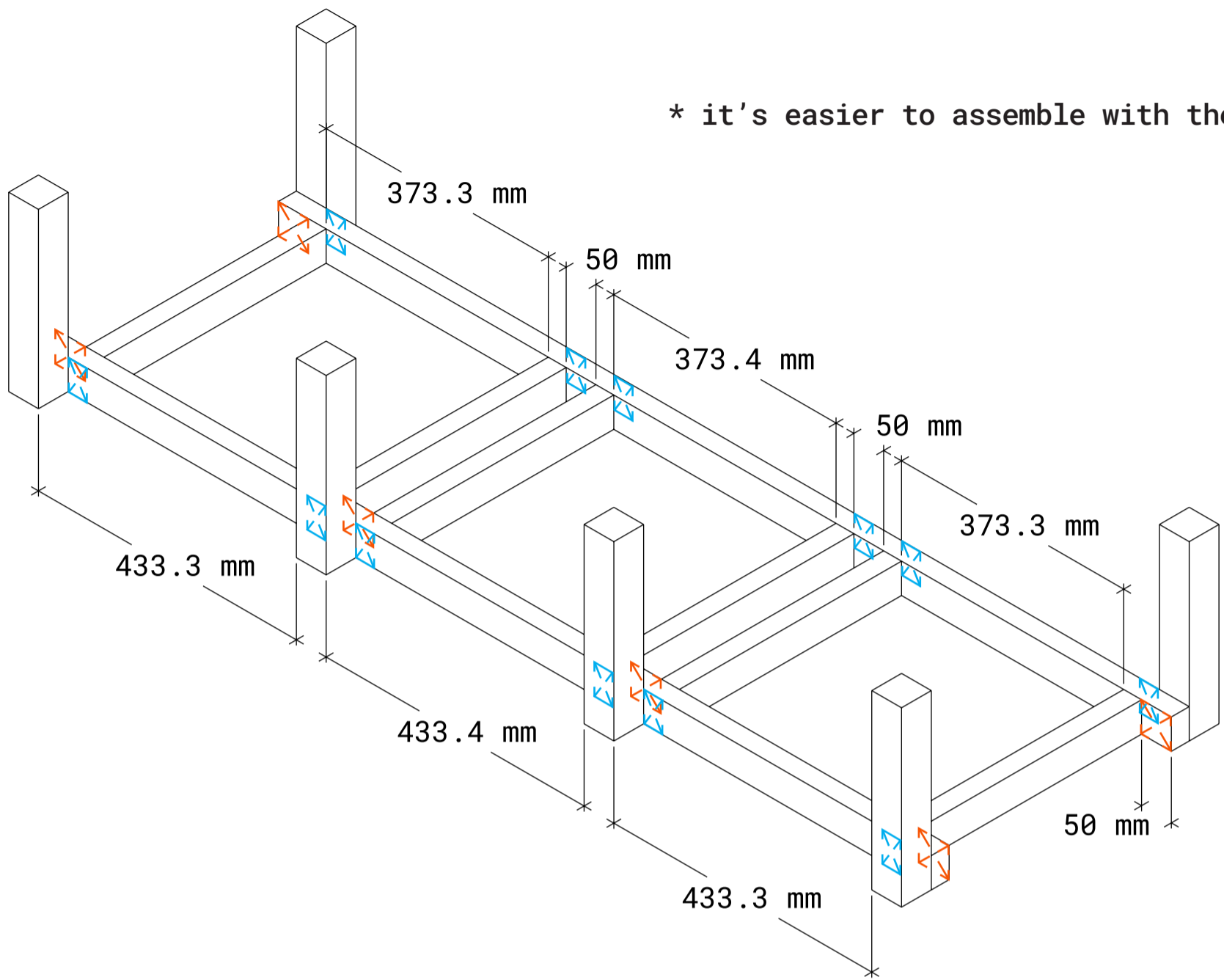

● legs-to-ladder,
use template #1

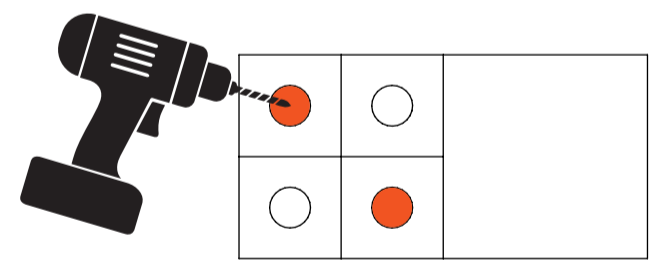

● beam connection,
use template #3

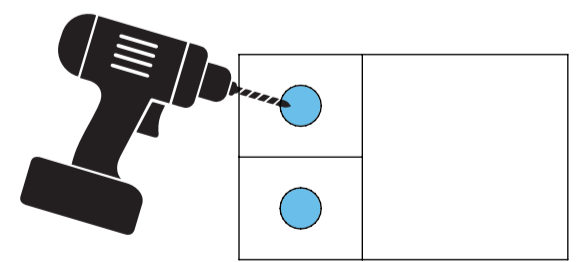

2

ladder

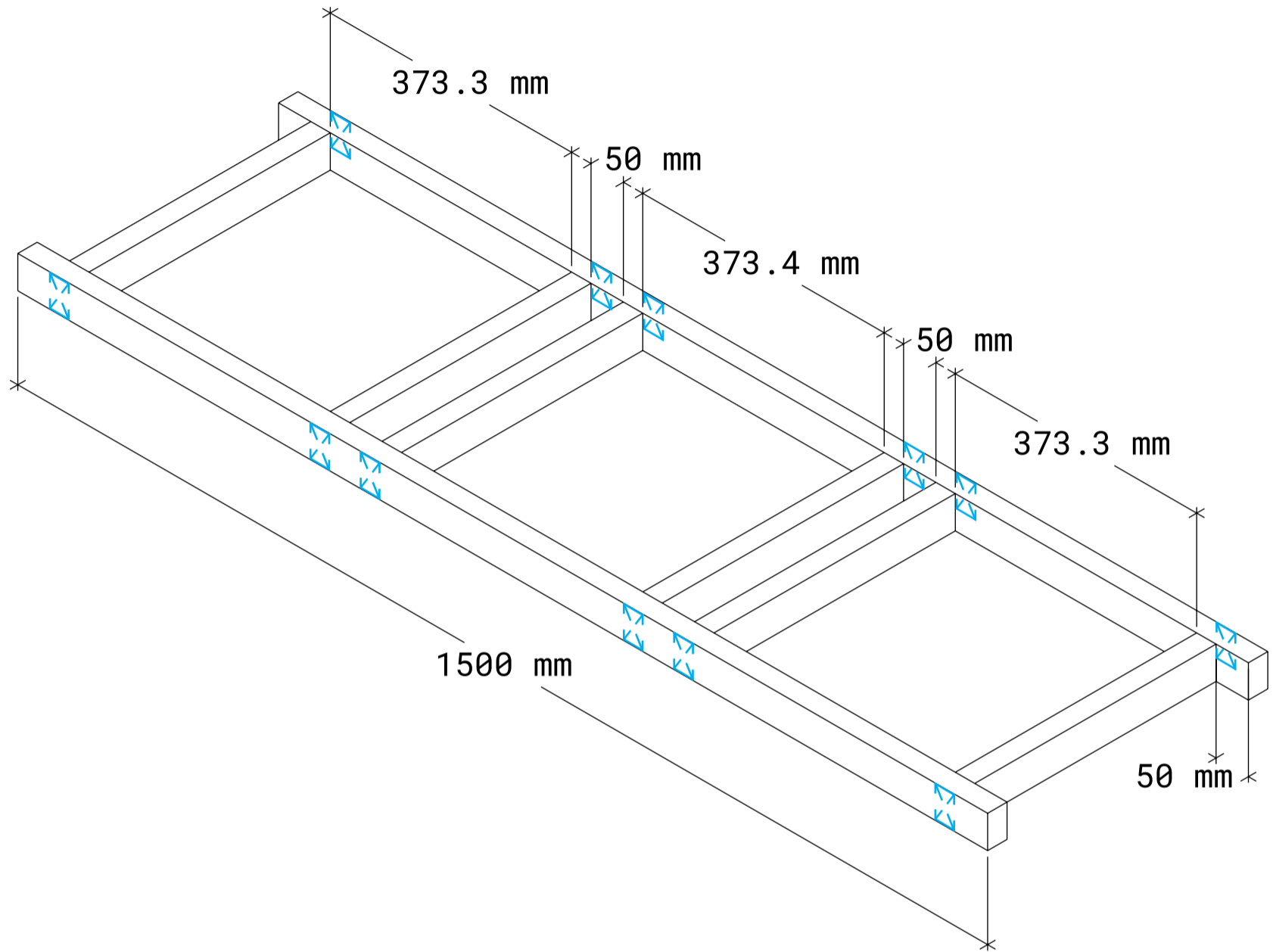

- beam connection, use template #3

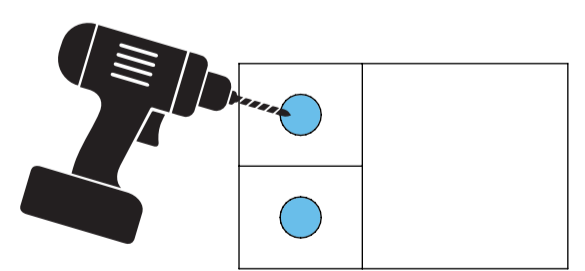

lower frame assembly

* all legs must be drilled crosswise on both sides!

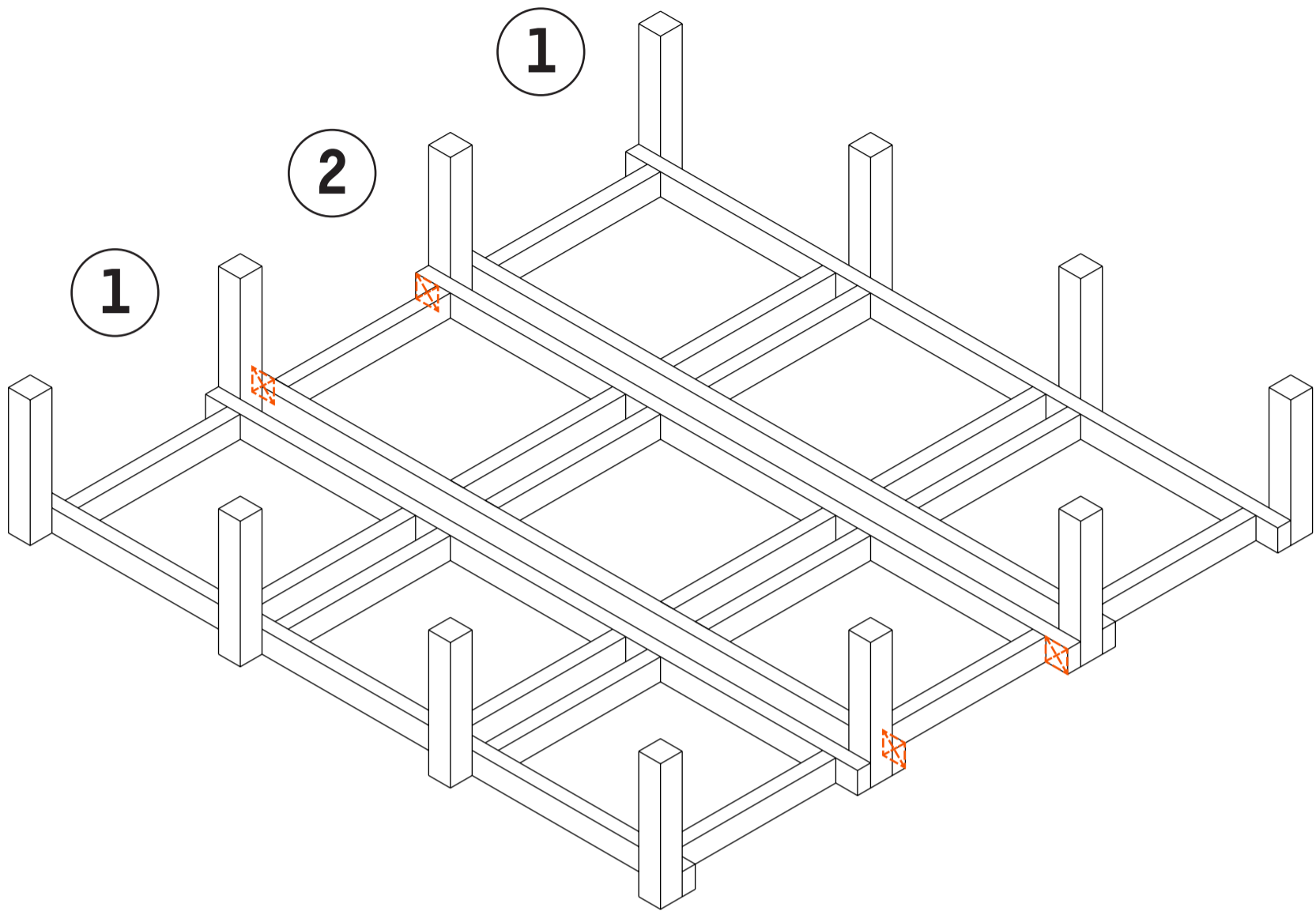

- legs-to-ladder, use template #1

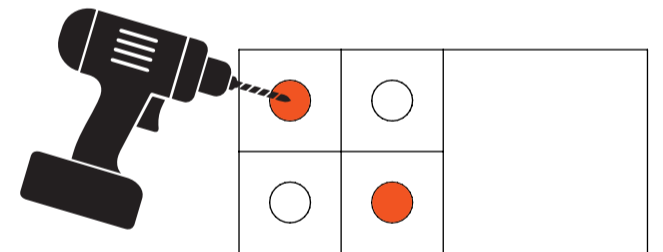

turn it over, put the frame on the legs

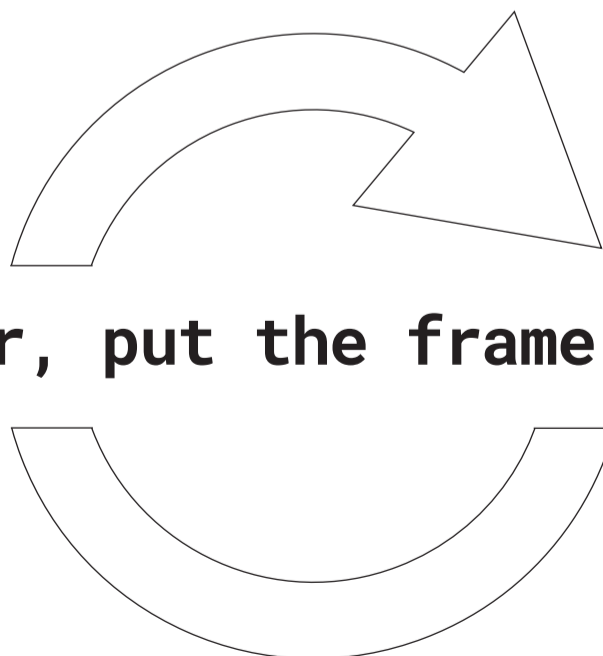

upper frame

what you will need:

timber: beam 50x50x1440 - 2 pcs.,
beam 50x50x453,3 - 4 pcs.,
beam 50x50x433,4 - 2 pcs.,
beam 50x30x1500 - 2 pcs.,
beam 50x30x1440 - 2 pcs.

screws: wood screws - 64 pcs.,
DIN571 screw 6,0x60 - 28 pcs.

other: metal corners - 16 pcs.,
template #3, instruments + forstner bit

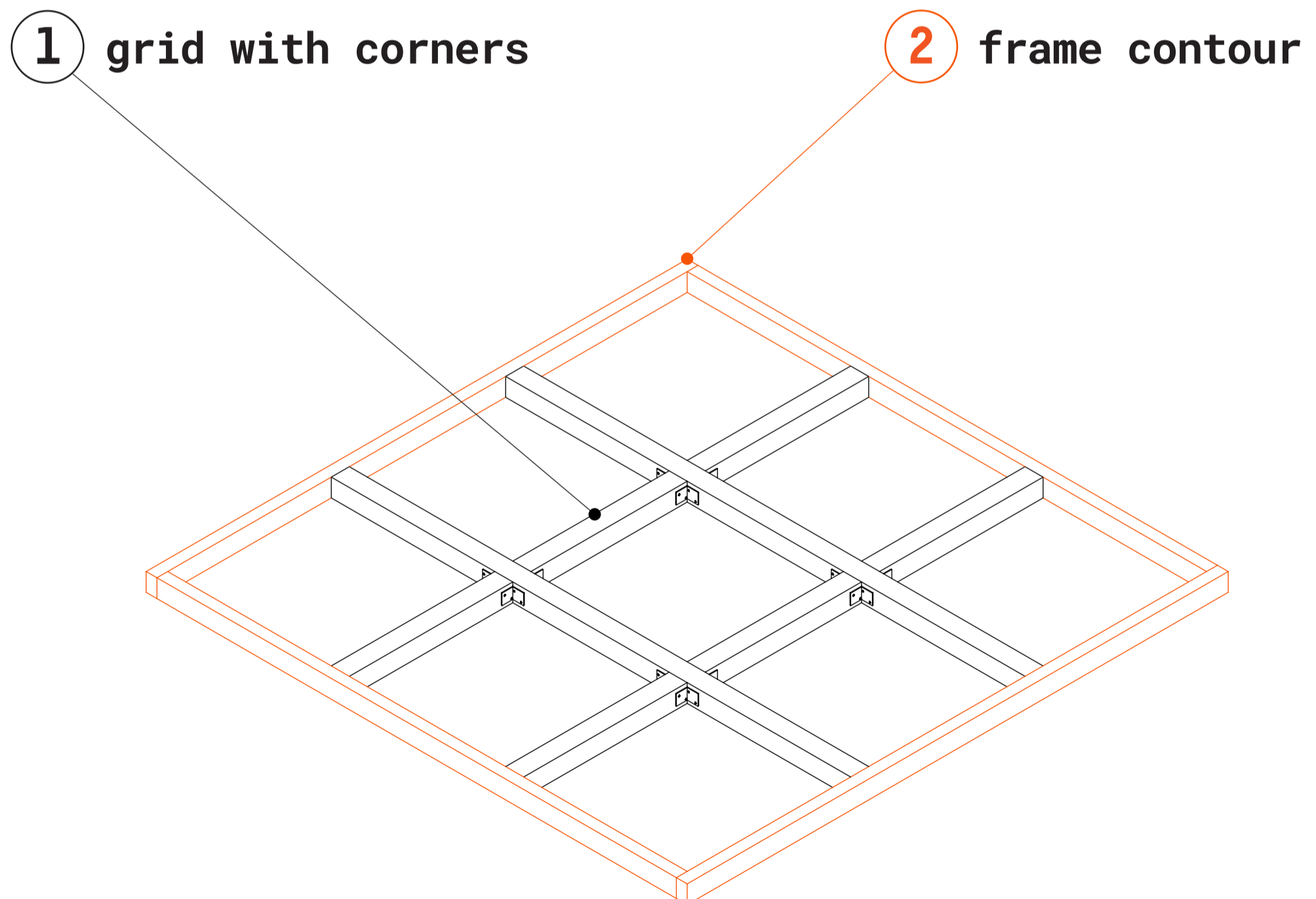

1 grid with corners

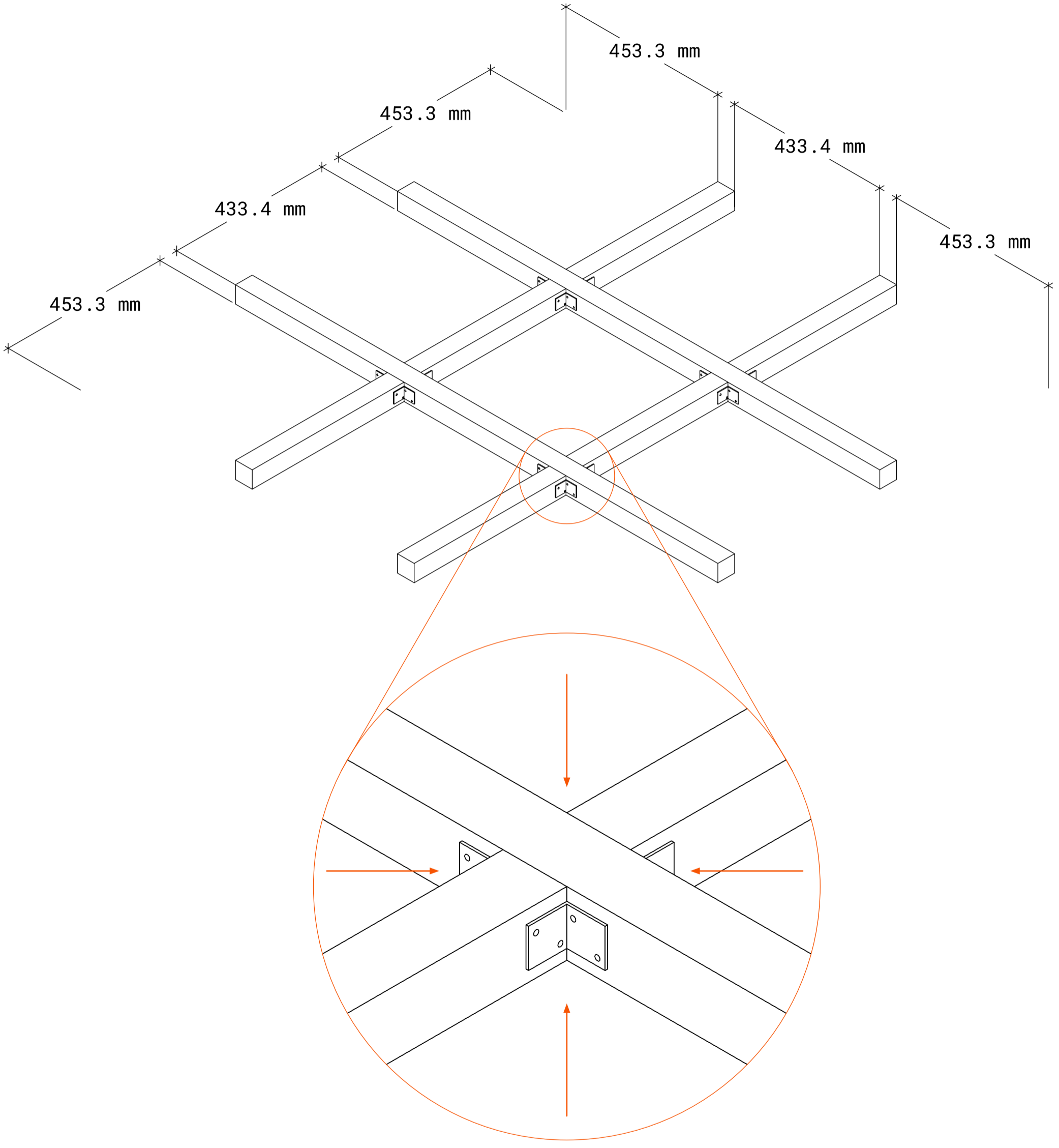

four corners for each cross,
fasten with ordinary wood screws

2

frame contour

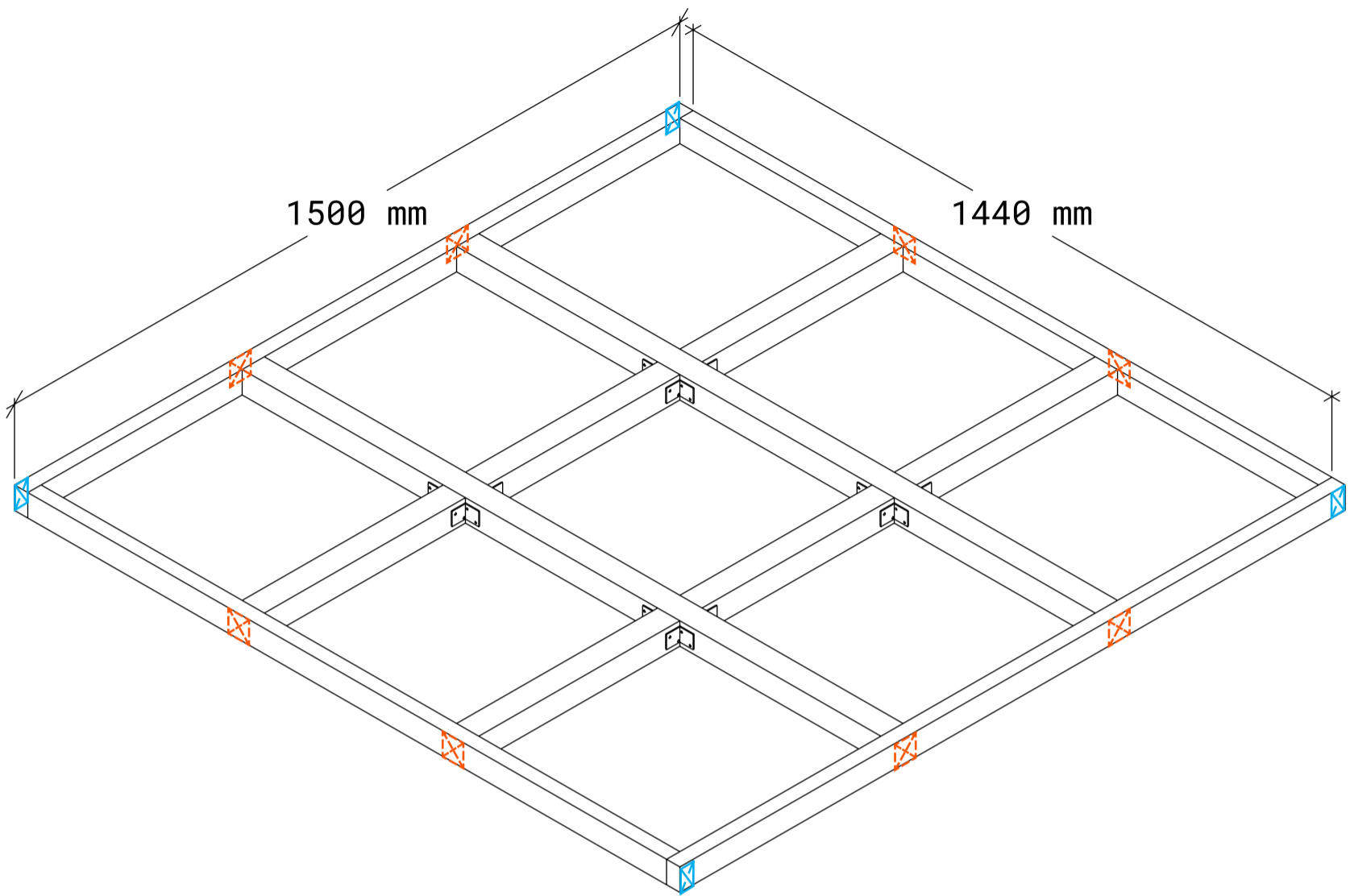

- frame contour-to-grid, use template #1

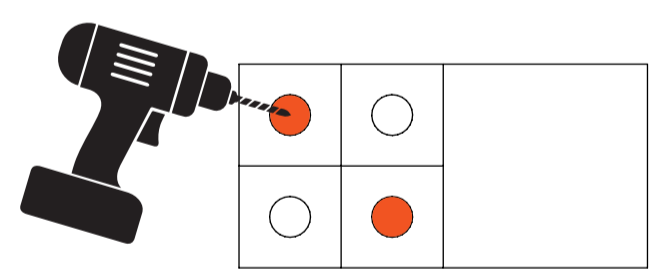

- frame contour connection, use template #3

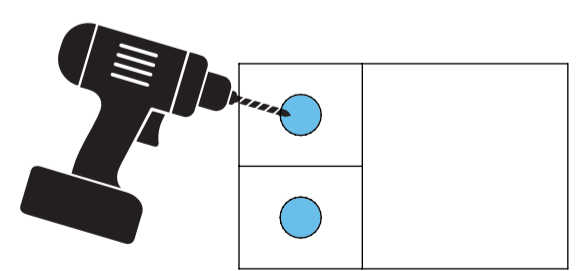

lower and upper frame connection

* when connecting the frames, the screw should hit the beam highlighted in orange

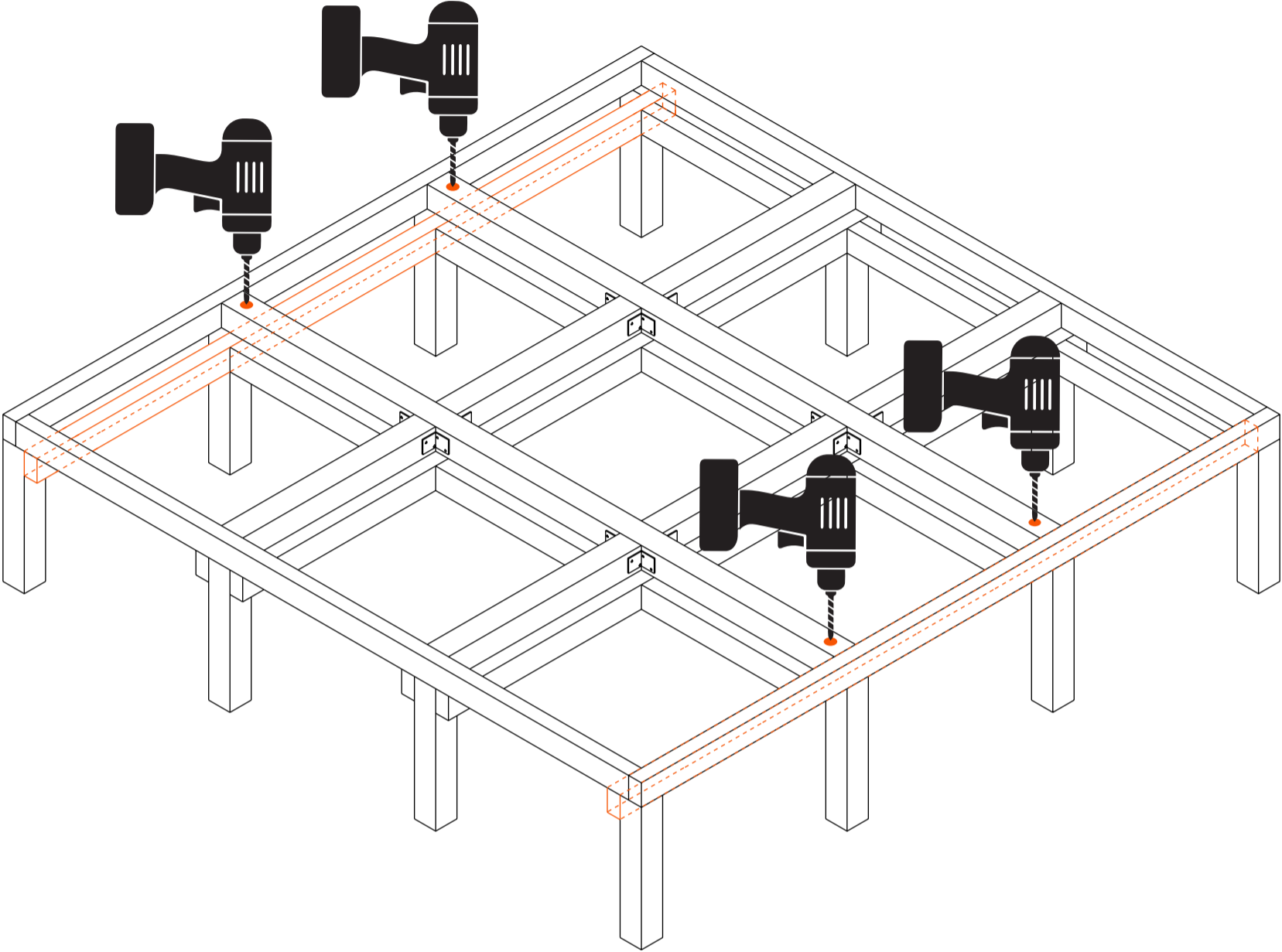

milling

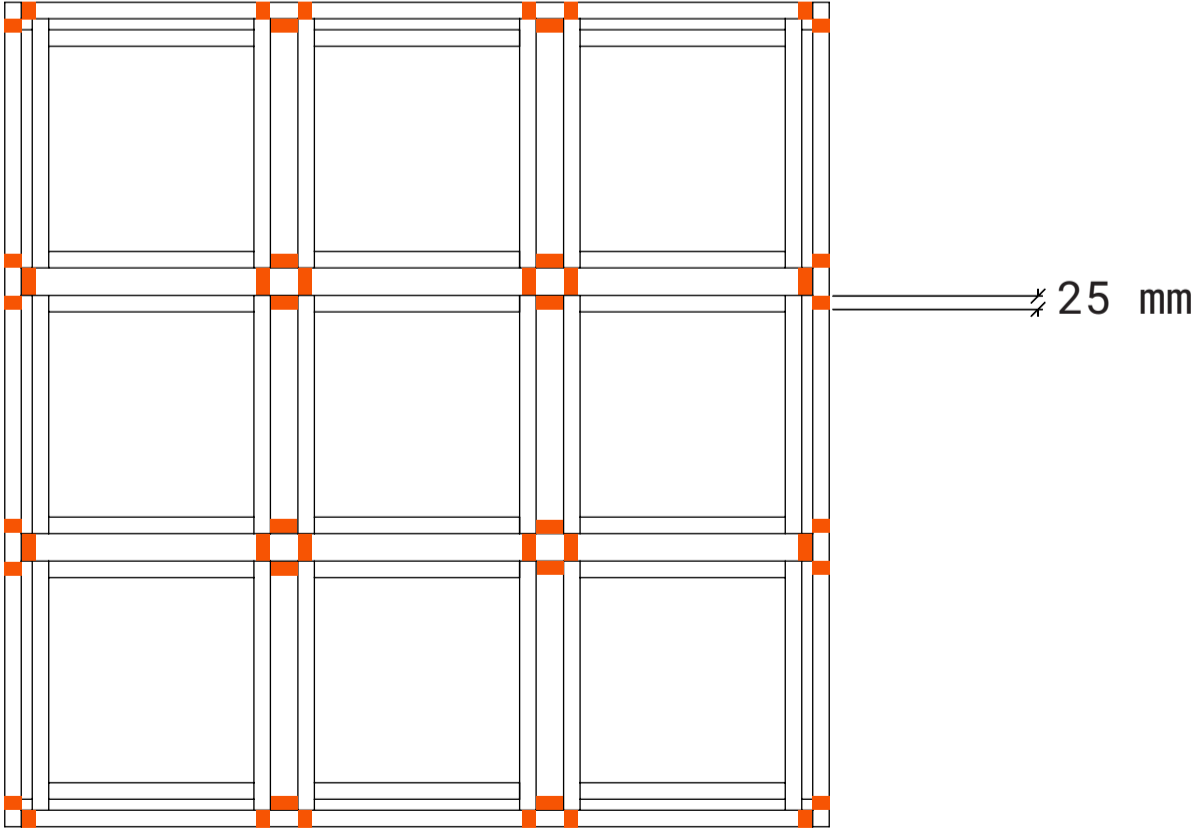

* milling is required only for the upper frame, milling depth ~ 10 mm

contour

what you will need:

timber: plank 30x50x1560 - 2 pcs.,
plank 30x50x1500 - 2 pcs.

screws: DIN571 screw 6,0x60 - 24 pcs.

other: template #1, #2, instruments + forstner bit

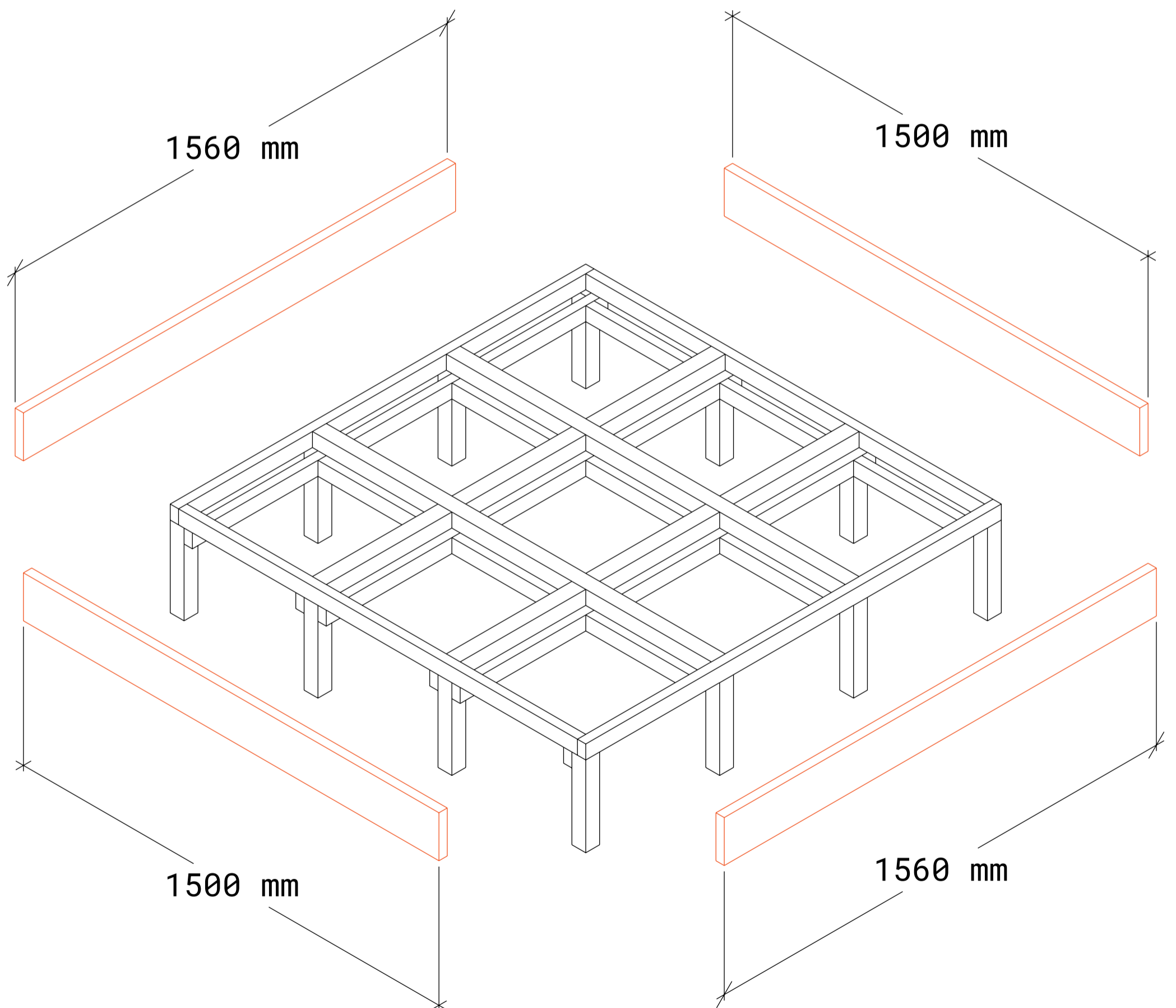

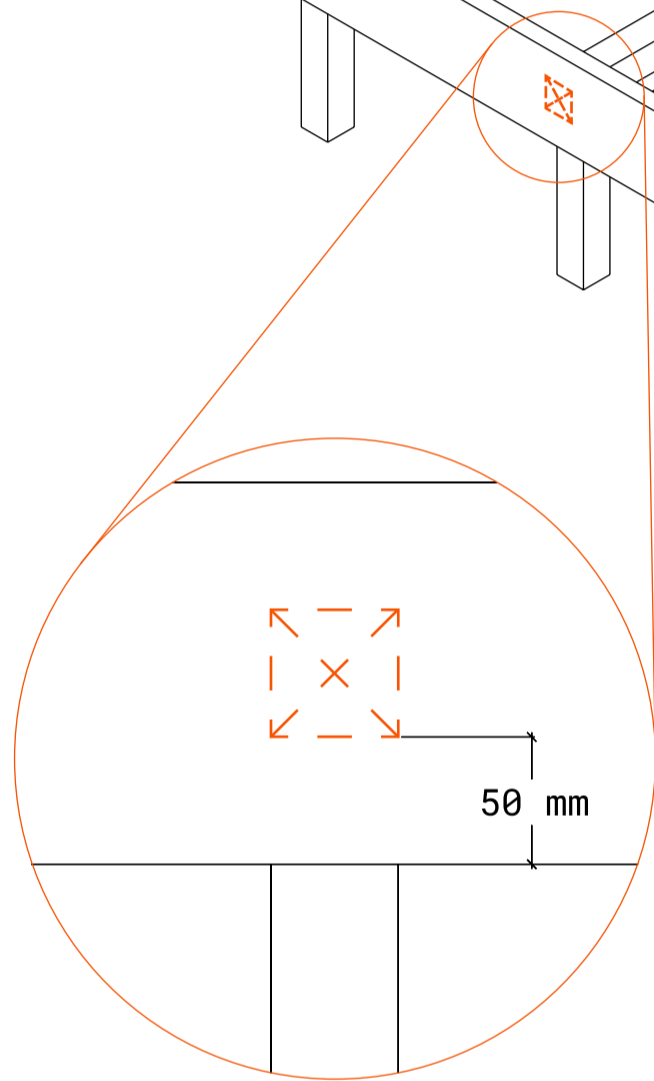
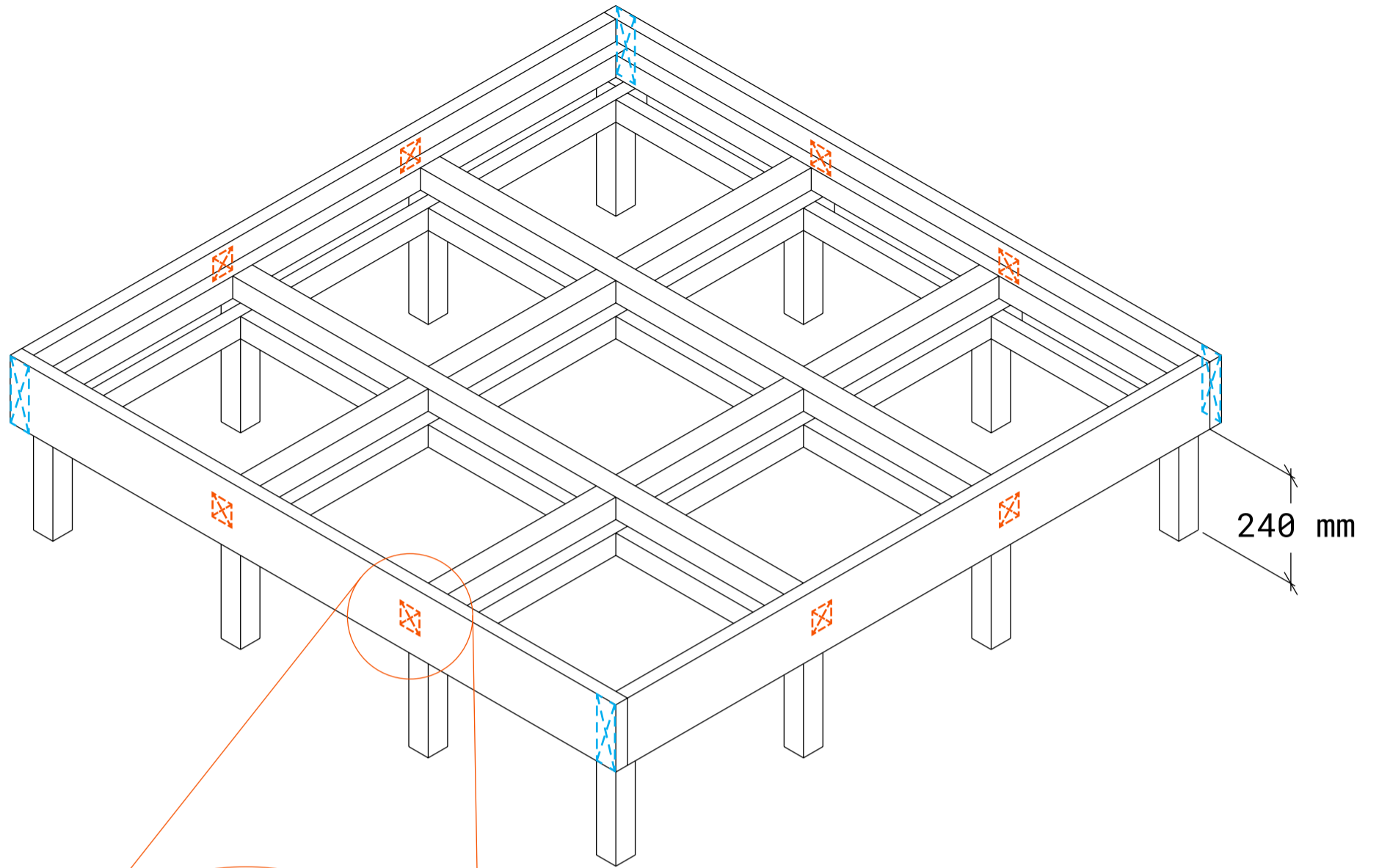

- **contour connection,
use template #2**

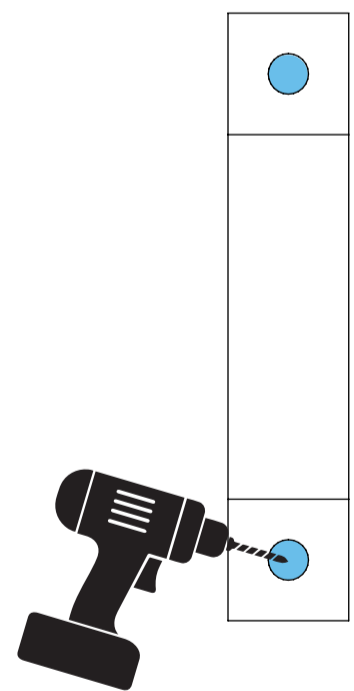

- **contour-to-frame,
use template #1**

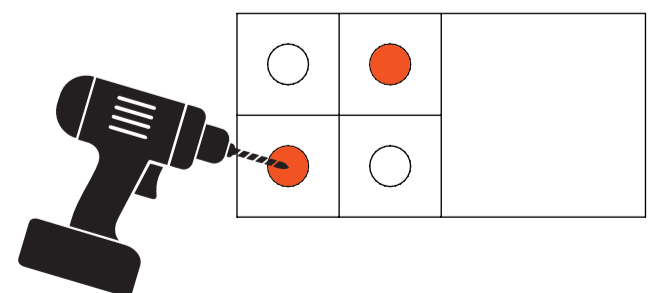

module

what you will need:

screws: bolt M8x100 8.8 - 18 pcs.,
wood screw 100 mm - 108 pcs.,
wood screw 45 mm - 144 pcs.,
washer 8 mm - 54 pcs.,
nut M8 8 mm - 18 pcs.

timber: plank 100x20x487 - 36 pcs.
beam 30x50x487 - 18 pcs.
beam 30x50x427 - 18 pcs.
beam 30x50x397 - 18 pcs.

other: template #2, #3, instruments + forstner bit

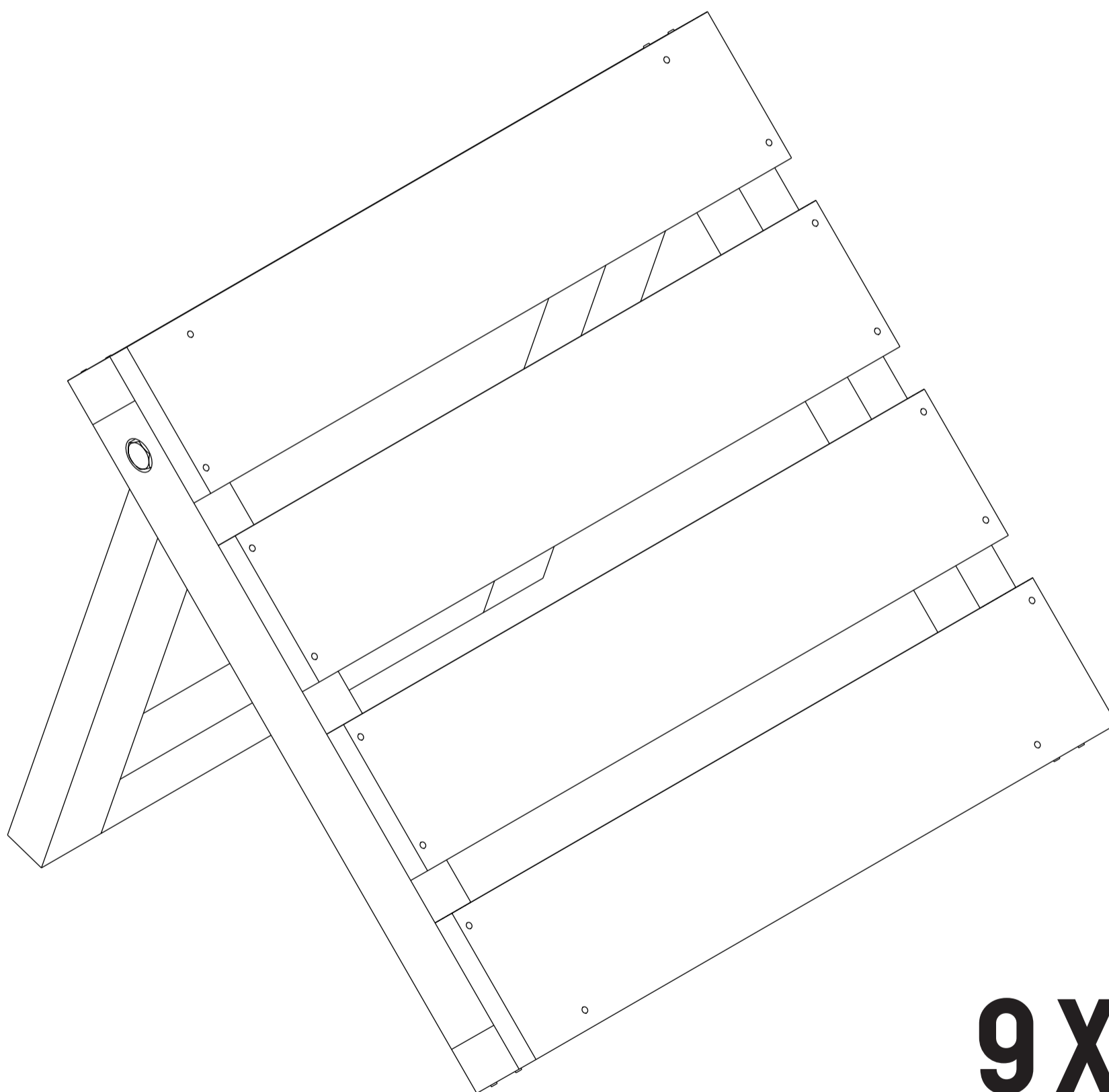

9X

* a custom pattern can be added to each of the modules for uniqueness or to adjust the platform to a specific context

3 top boarding

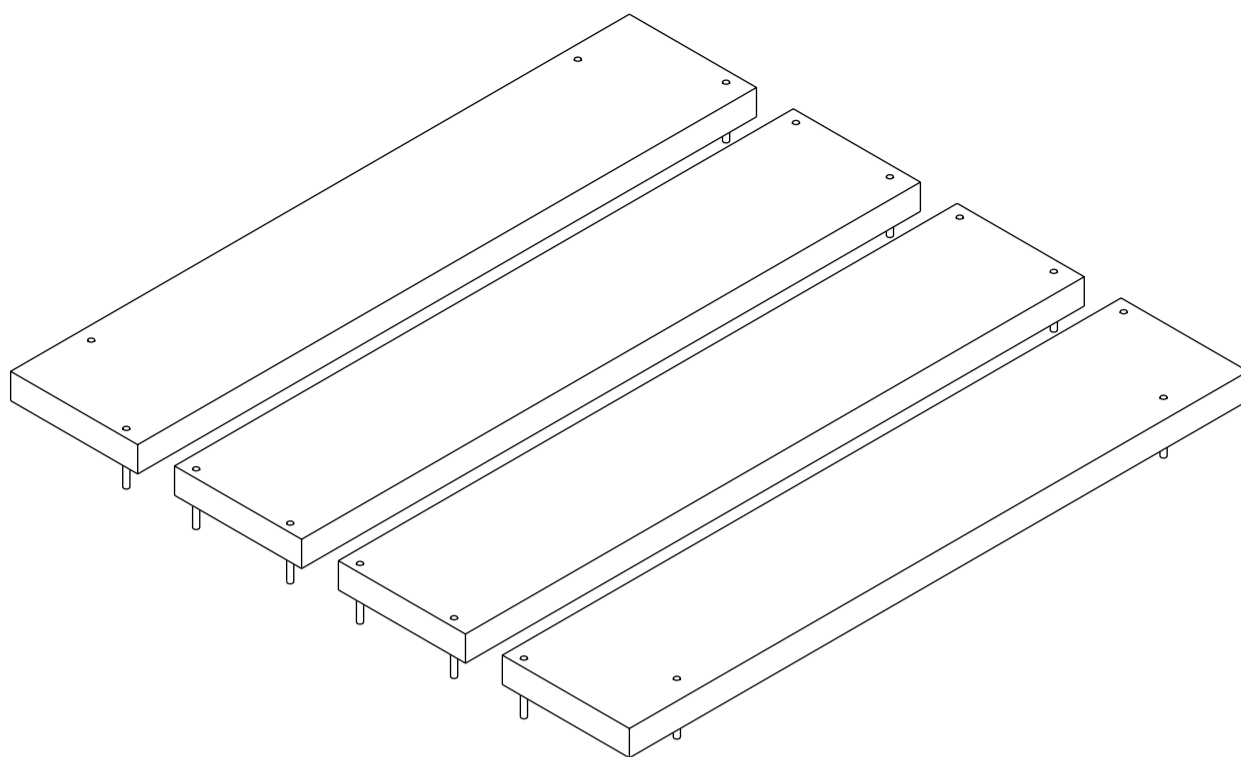

2 base frame

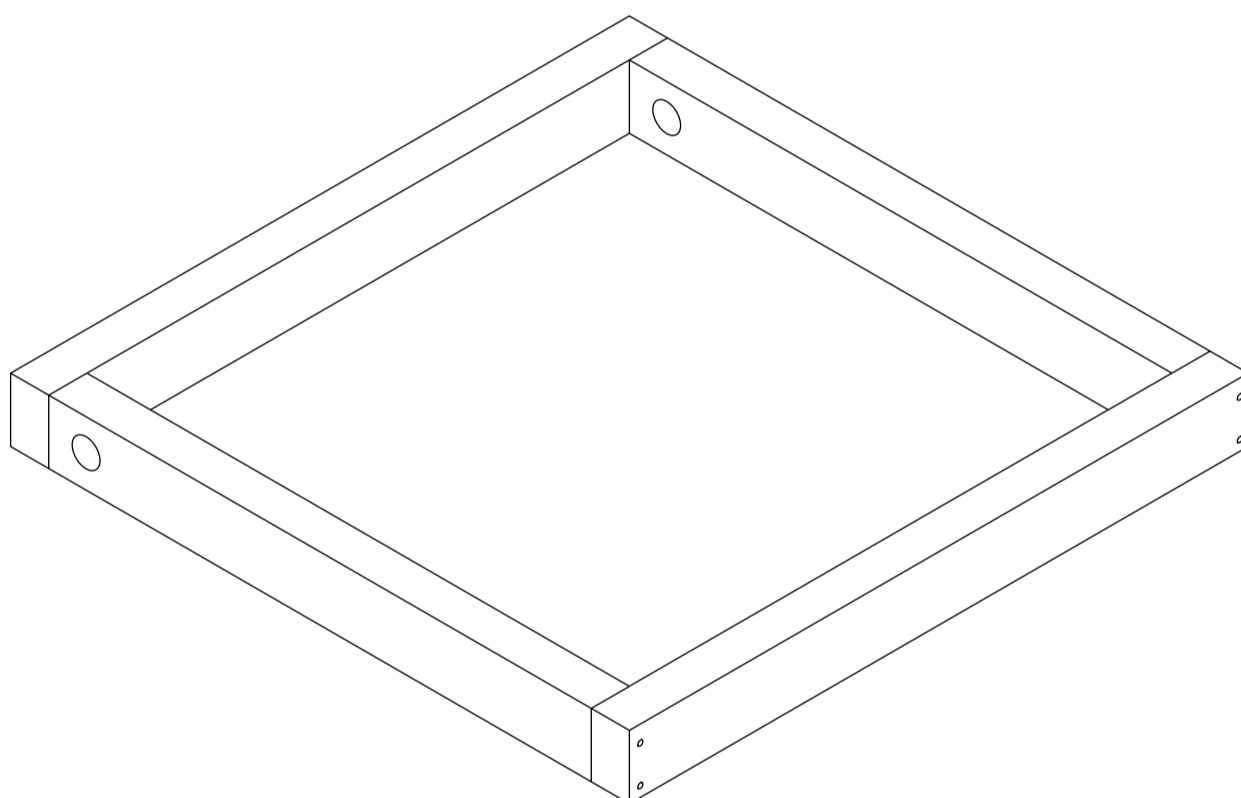

1 movable leg

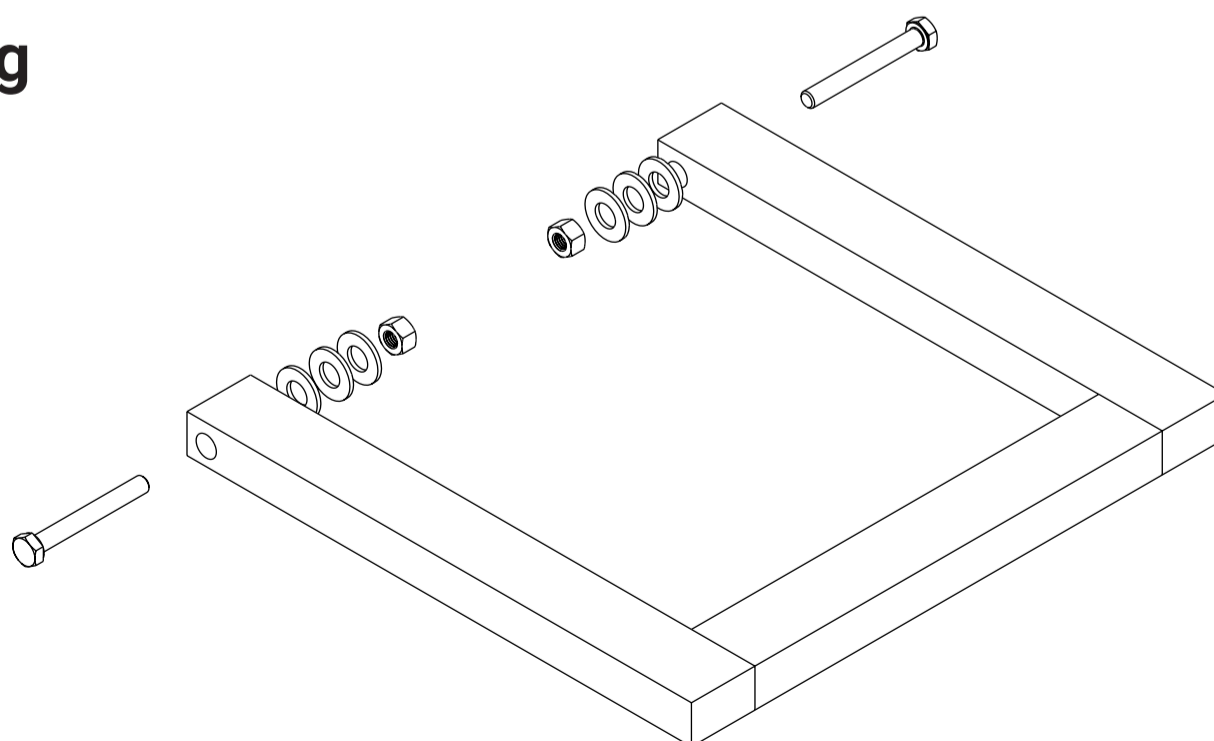

1

movable leg

* for assembly use 100 mm wood screws

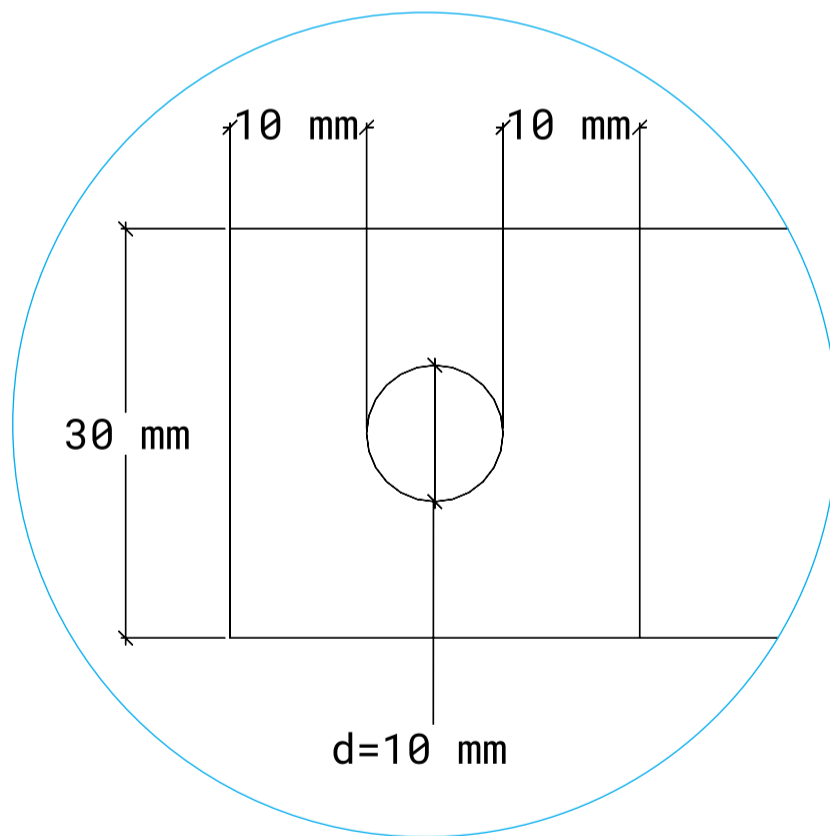
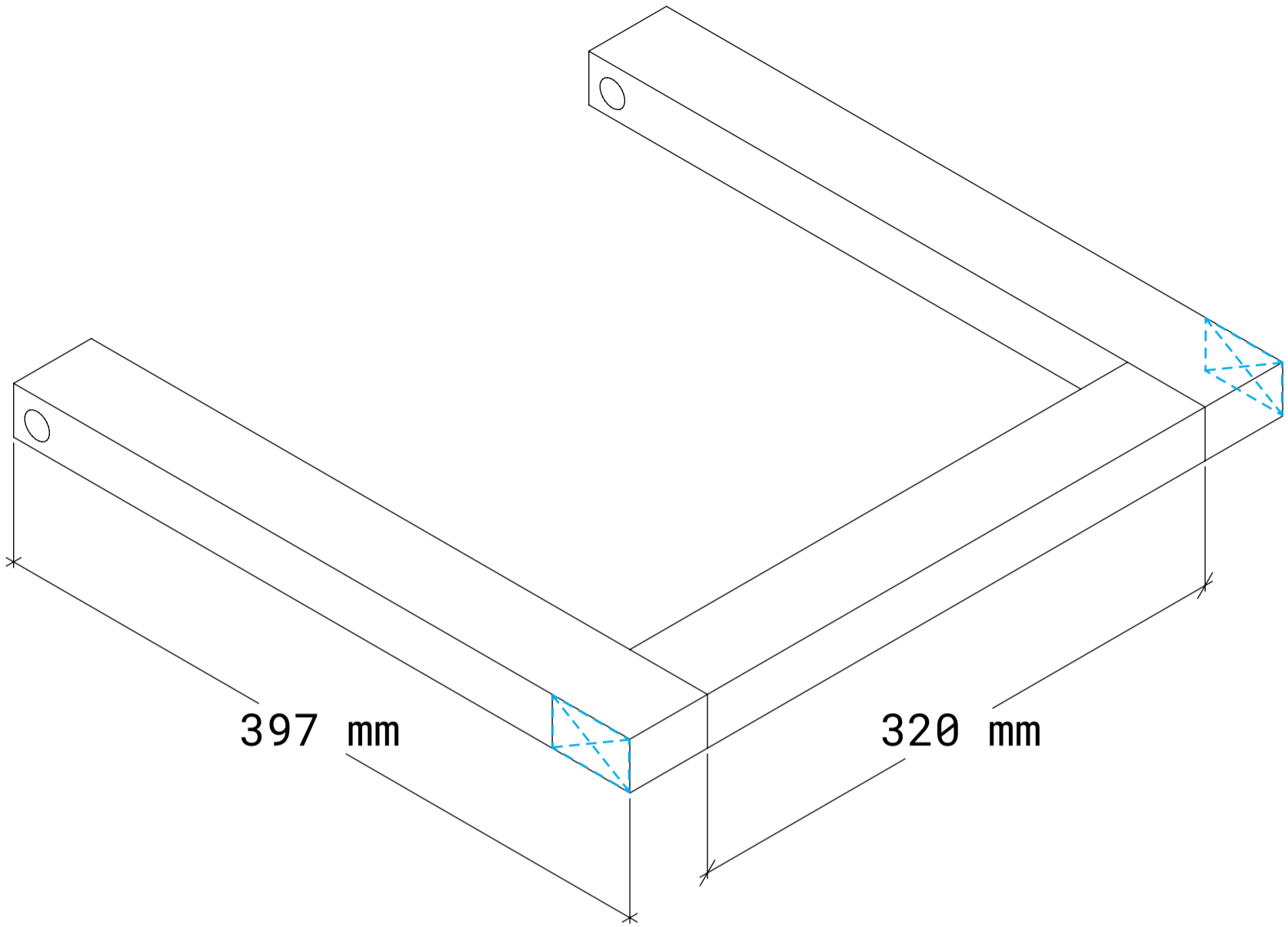

- beam connection, use template #3

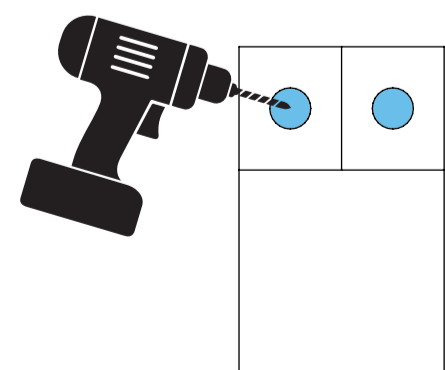

2

base frame

* for assembly use 100 mm wood screws

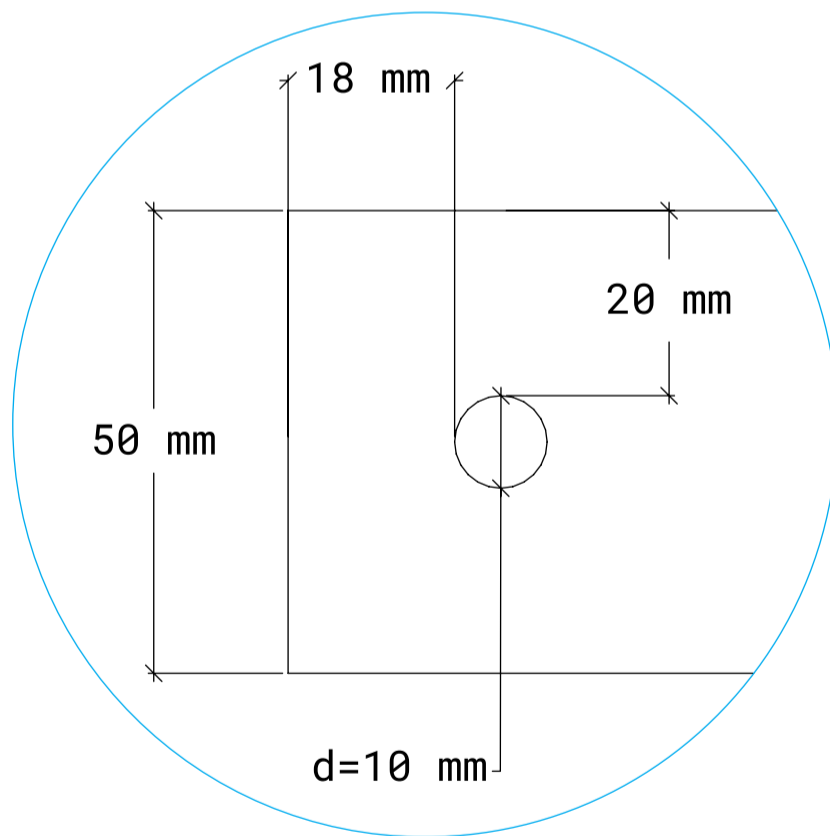
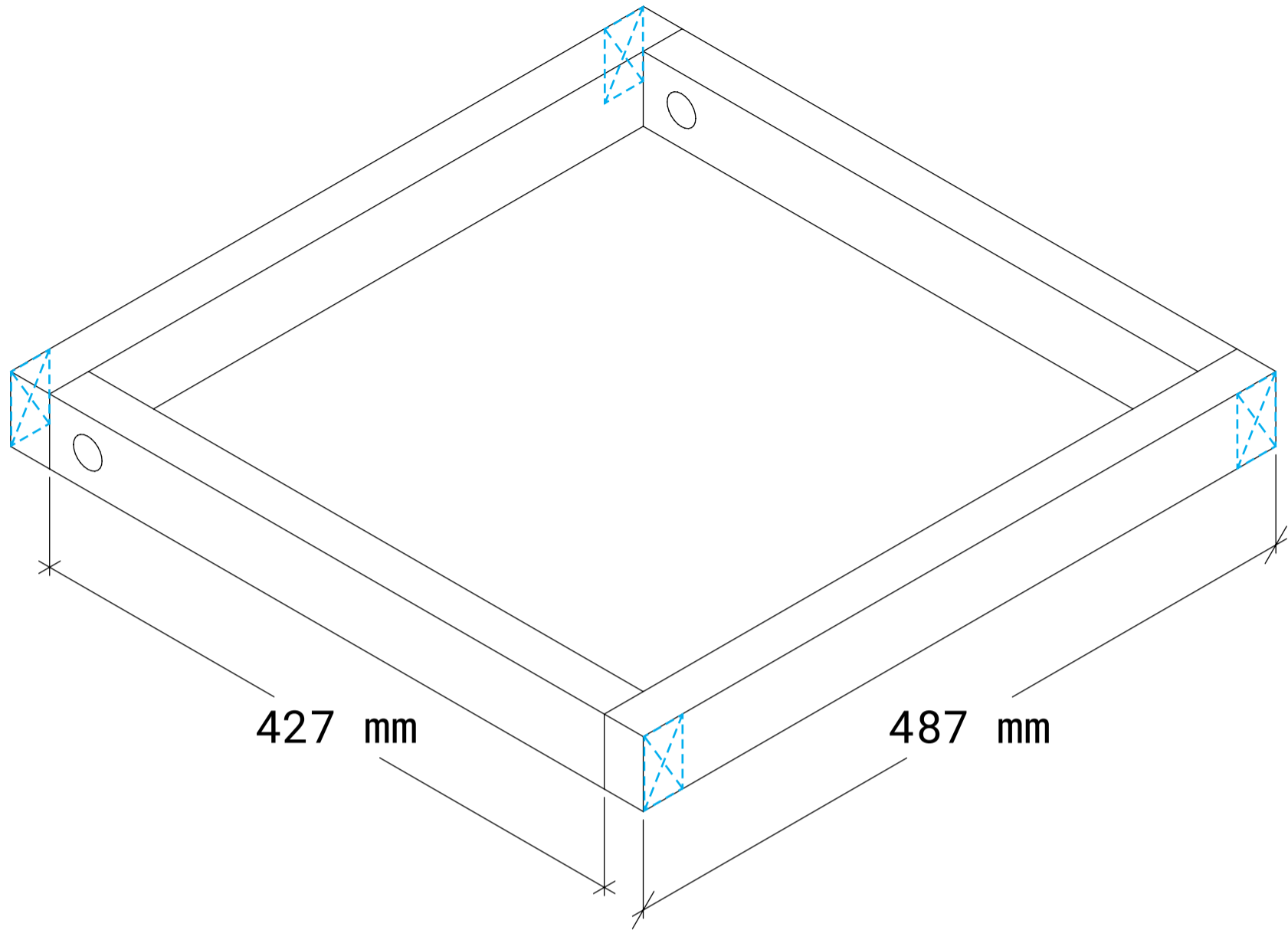

- beam connection, use template #3

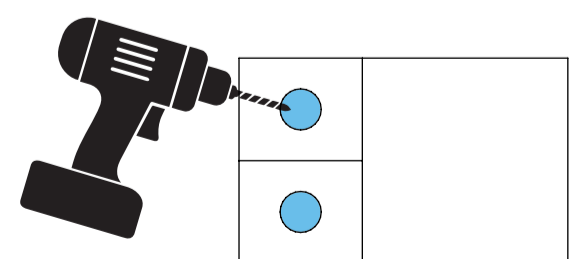

attaching the leg to the base

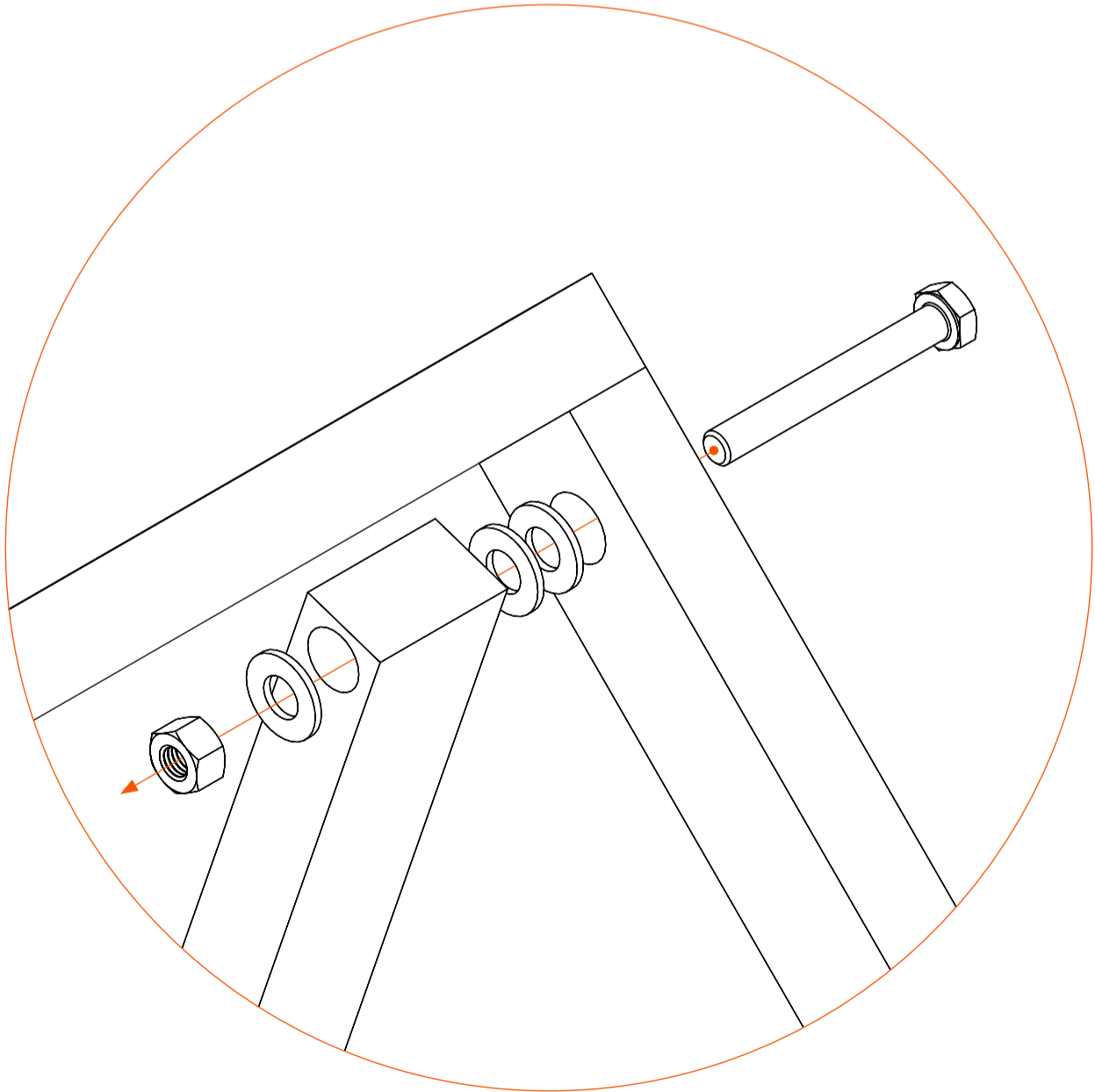
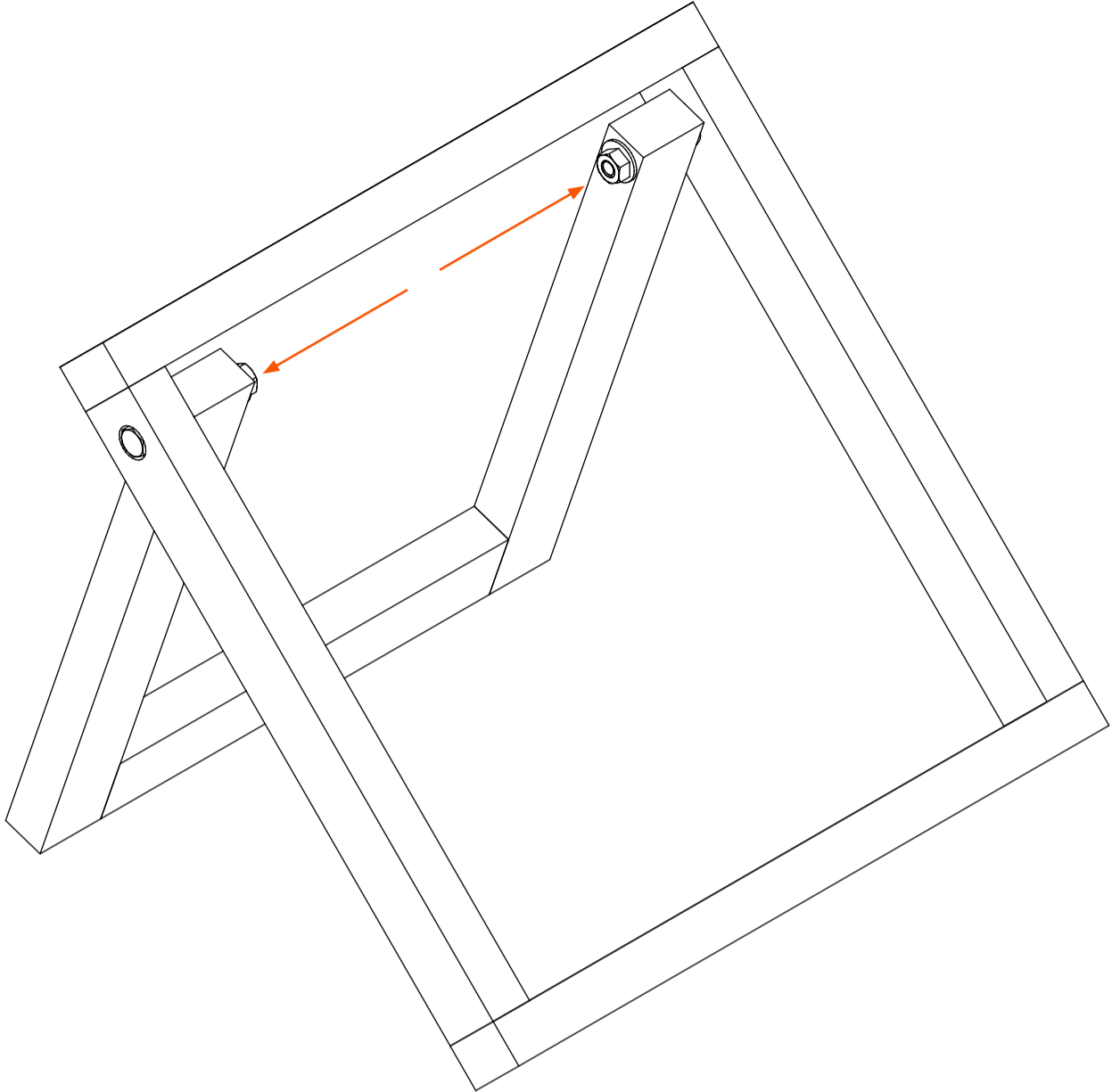

3

top boarding

* screw the boards parallel to the movable leg

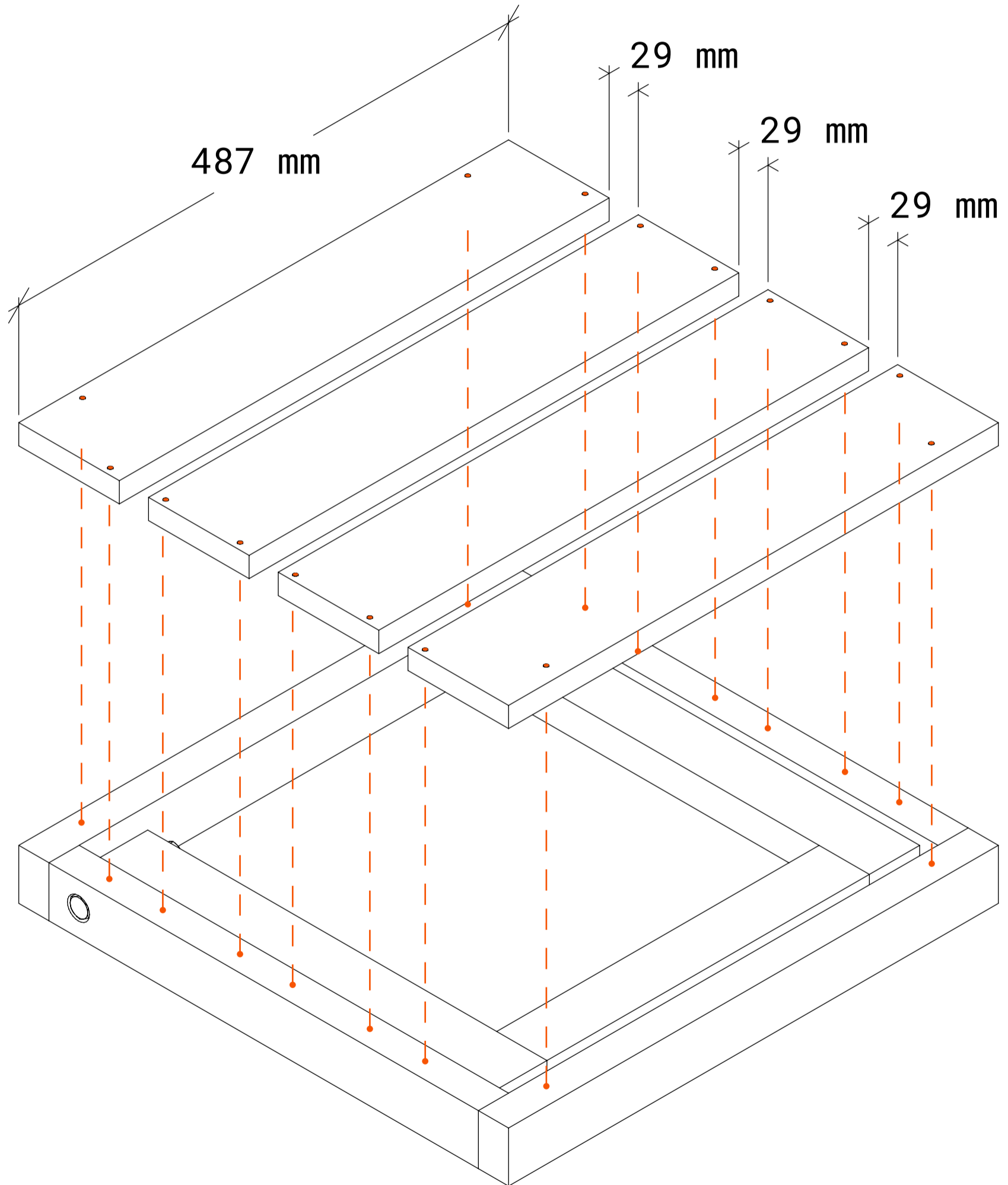

* before screwing the boards to the base,
you can mill sharp corners for greater convenience

sketchup model

